

Power Flow Control in Transmission Line using UPFC Equipped with Fuzzy Logic Controller

M. LIKHITHA KATHYAYANI¹, NUNAVATH SHANKAR²

¹PG Scholar, Dept of EEE, SBIT, Warangal, Telangana, India.

²Assistant Professor, Dept of EEE, SBIT, Warangal, Telangana, India.

Abstract: Flexible AC transmission system (FACTS) devices uses power electronics components to maintain controllability and capability of electrical power system FACTS controller includes unified power flow controller (UPFC), Static synchronous compensators (STATCOMs), Thyristor controlled series compensators (TCCs), Static series synchronous compensators (SSSCs) and Static VAR compensators (SVCs), are able to modify voltage, phase angle and impedance at particular bus in a power system. The (UPFC) is the most versatile and complex power electronic equipment that has emerged for the control and optimization of power flow in electrical power transmission system. In this paper we see how the UPFC increases the transmission capacity and reduce the power congestion in the transmission line. This paper shows the results that we obtained by implementing a Transmission system in MATLAB Simulink by using UPFC and without using UPFC.

Keywords: FACTS, (UPFC), AC Transmission System, Power Flow Control, STATCOM, SSSC.

I. INTRODUCTION

The unified power flow controller (UPFC) is one of the most widely used FACTS controllers and its main function is to control the voltage, phase angle and impedance of the power system thereby modulating the line reactance and controlling the power flow in the transmission line. The basic components of the UPFC are two voltage source inverters (VSIs) connected by a common dc storage capacitor which is connected to the power system through a coupling transformers. One (VSIs) is connected in shunt to the transmission system through a shunt transformer, while the other (VSIs) is connected in series to the transmission line through a series transformer. Three phase system voltage of controllable magnitude and phase angle (V_c) are inserted in series with the line to control active and reactive power flows in the transmission line. So, this inverter will exchange active and reactive power within the line. The shunt inverter is operated in such a way as to demand this dc terminal power (positive or negative) from the line keeping the voltage across the storage capacitor (V_{dc}) constant. So, the net real power absorbed from the line by the UPFC is equal to the only losses of the inverters and the transformers. The remaining capacity of the shunt inverter can be used to exchange reactive power with the line so to provide a voltage regulation at the connection point.

The two VSI's can work independently from each other by separating the dc side. So in that case, the shunt inverter is operating as a (STATCOM) that generates or absorbs reactive power to regulate the voltage magnitude at the connection point. The series inverter is operating as (SSSC) that generates or absorbs reactive power to regulate the

current flowing in the transmission line and hence regulate the power flows in the transmission line. The UPFC has many possible operating modes. (1)VAR control mode:-The reference input is a simple var request that is maintained by the control system regardless of bus voltage variation. (2) Automatic voltage control mode:-The shunt inverter reactive current is automatically regulated to maintain the transmission line voltage at the point of connection to a reference value with a defined slope characteristics the slope factor defines the per unit voltage error per unit of inverter reactive current within the current range of the inverter. In Particular, the shunt inverter is operating in such a way to inject a controllable current into the transmission line. The fig.1 shows how the (UPFC) is connected to the transmission line.

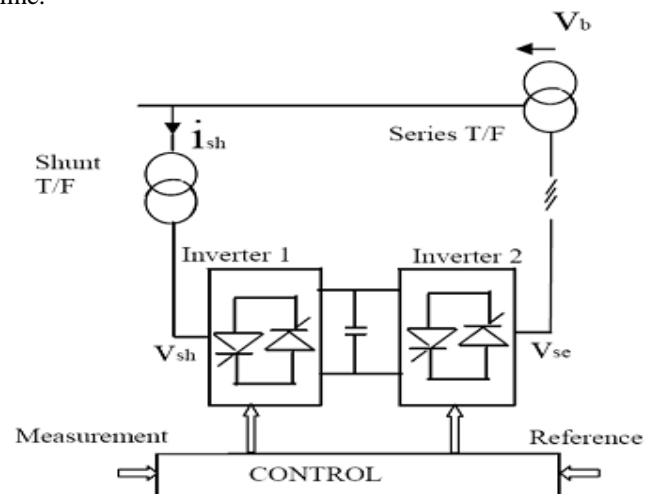

Fig.1. UPFC installed in a transmission line.

Fig.2 Shows the Single line diagram of a 500kv/230kv transmission system using UPFC. The power flow in a 500 kV /230 kV transmission systems is shown in single line in fig2. The system is connected in a loop configuration, consists of five bus (B1 to B5) interconnected through three transmission lines (L1, L2, L3) and two 500 kV/230 kV transformer banks Tr1 and Tr2. Two power plants located on the 230 kV system generate a total of 1500 MW (illustrated in fig.2) which is transmitted to a 500 kV, 15000 MVA equivalent and to a 200 MW load connected at bus B3. Each plant model includes a speed regulator, an excitation system as well as a power system stabilizer (PSS). In normal operation, most of the 1200 MW generating capacity power plant P1 is exported to the 500 kV equivalents through two 400 MVA transformer connected between buses B4 and B5.

500 kV / 230 kV Transmission System

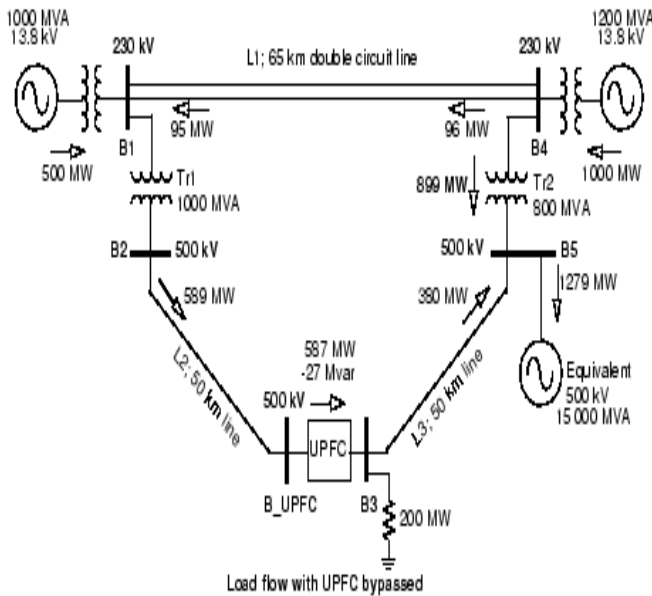

Fig.2. The Single line diagram of a 500kv/230kv transmission system using UPFC.

The UPFC is connected at the right end of line L2 is used to control the active and reactive power at the 500kv bus B3 the UPFC used here include two 100 MVA, IGBT based converters (one series converter and one shunt converter) both the converter are interconnected through a DC bus two voltage source inverter connected by a capacitor charged to a DC voltage realize the UPFC the converter number one which is a shunt converter draws real power from the source and exchange it (minus the losses) to the series converter the power balance between the shunt and series converter is maintained to keep the voltage across the DC link capacitor constant. The single line diagram is implemented on MATLAB Simulink. The series converter is rated 100MVA with a maximum voltage injection of 0.1pu the shunt converter is also rated 100MVA the shunt converter is operated in voltage control mode and the series converter is operated in power flow control mode the series converter can inject a maximum of 10% of nominal line to ground voltage. The real and reactive power equations are as follows:

$$P = \frac{V_1 V_2}{X} \sin(\delta_1 - \delta_2) \tag{1}$$

$$Q = \frac{V_2}{X} (V_1 - V_2) \tag{2}$$

Fig.3 shows MATLAB Simulink model of single line diagram of transmission System without using UPFC.

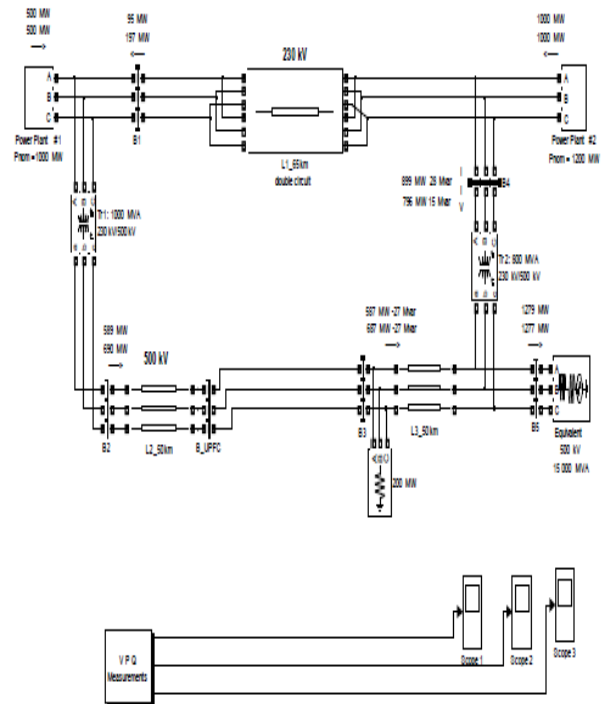

Fig.3. MATLAB Simulink model of single line diagram transmission system using UPFC.

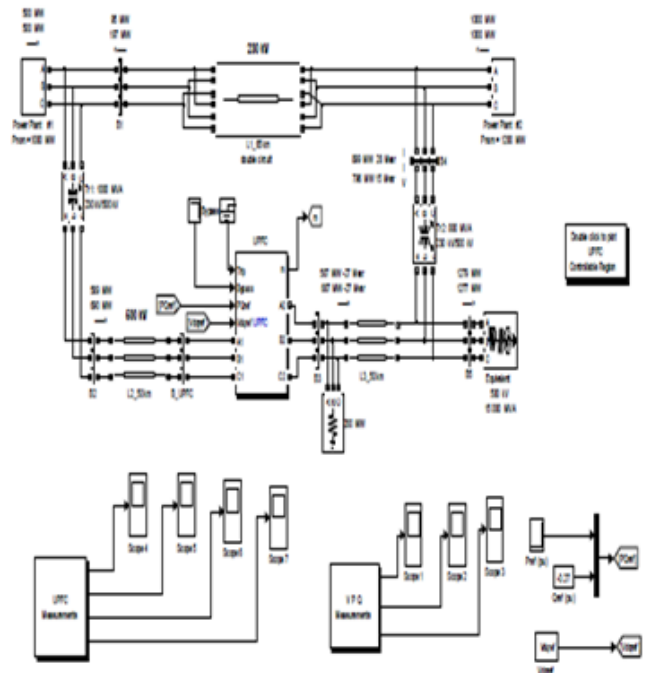

Fig.4.

Series injected voltage in pu through a (VSIs) connected in series to the transmission line Through a series transformer without using UPFC as shown in Fig.5.

Note: X-axis represents time in second and Y-axis represents series injected voltage in pu For both UPFC and without UPFC.

Power Flow Control in Transmission Line using UPFC Equipped with Fuzzy Logic Controller

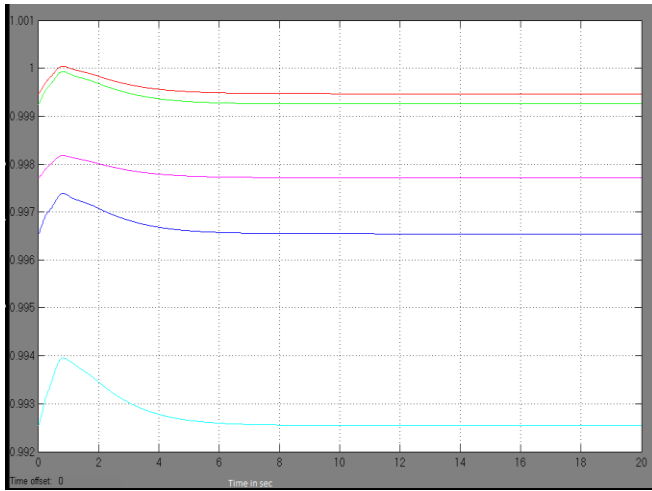

Fig.5. Graphical result without using UPFC

Series injected voltage in pu through a (VSI) connected in series to the transmission line through a series transformer using UPFC as shown in Fig.6.

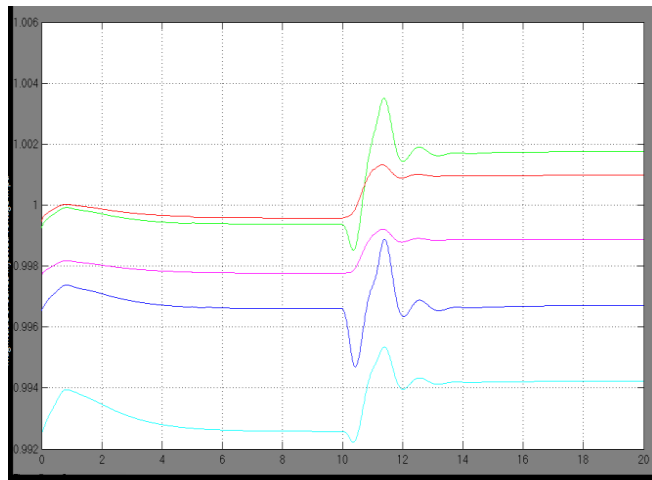

Fig.6. Graphical result by using UPFC.

Graphical results show the comparison between the real power flows in the transmission line with and without and using UPFC as shown in Fig.7.

Note: Y-axis represents the real power in MW.

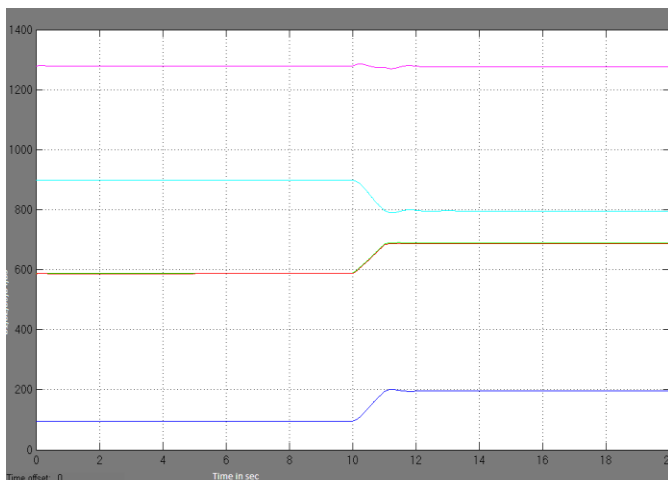

Fig.7. Graphical result by using UPFC.

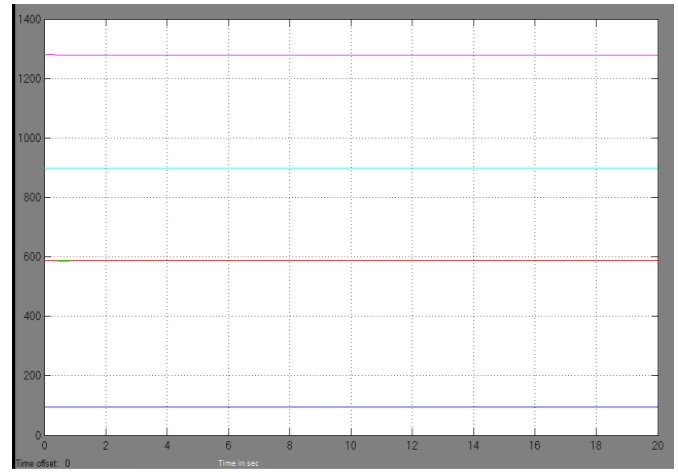

Fig.8. Graphical result without using UPSC.

Comparison between reactive power flows in the transmission line with and without using UPFC as shown in Figs.8 to 10.

Note: Y-axis represents the reactive power in MVAR.

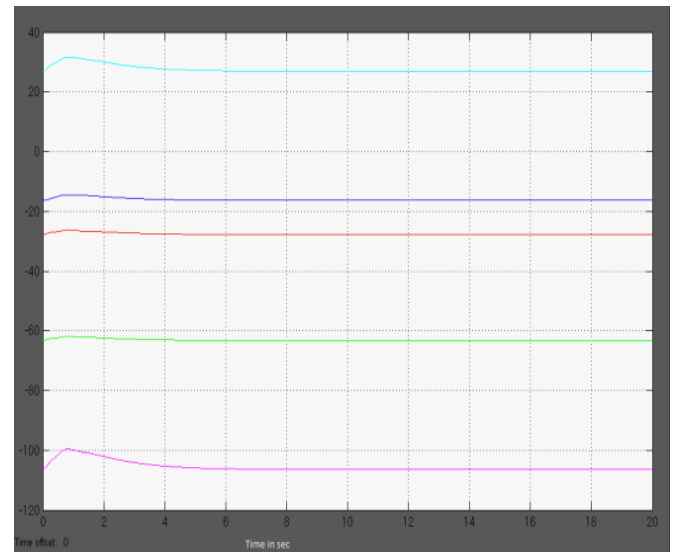

Fig.9. Graphical result Without using UPFC.

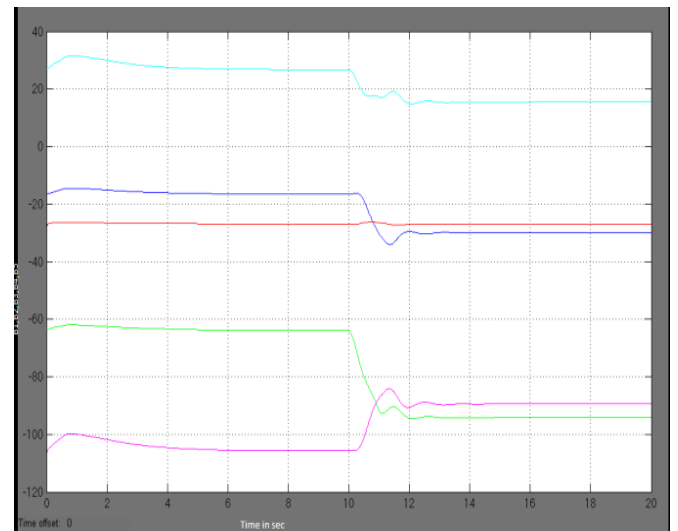

Fig.10. Graphical result by using UPFC.

II. RESULTS

In the single line diagram the (UPFC) is connected to bus B3 and the simulink results thus we obtain shows that how the(UPFC) reduces the reactive power in the line, without using(UPFC)the reactive power at bus B3 is -27 MVAR and real power at bus B3 is 587MW and remain constant up to t=20sec. but with (UPFC)for a series voltage injection from 0.0094 to 0.1 pu at t= 10 sec the angle of injected voltage start varying at a rate of 45deg/sec the shunt converter is in voltage control mode and the series converter is in power flow control mode the (UPFC) active and reactive power are set in magenta blocks labeled Pref(pu) and Qref(pu) initially the bypass breaker is closed and the resulting power flow at bus B3 is 587MW and the reactive power flow is -27Mvar at t=10sec when the breaker opened the net real power of the(UPFC) is increased by 100MW. The increase in real power tends to decrease the congestion on bus 5 this can be seen from the simulink result thus we obtained above when the breaker opened the oscillation of reactive power was finished and the reactive power was then constant at -27Mvar. after t=10sec the real power increased by 100MW i.e. from 587MW to 687MW.

III. CONCLUSION

It is necessary to maintain the voltage magnitude, phase angle and line impedance of the transmission system. In this paper the (UPFC) simulation study, matlab simulink is used to simulate the model of UPFC connected to a 3 phase transmission system. This paper presents the control & performance of the UPFC used for power quality improvement. The real and reactive powers increase with the increase in angle of injection. Simulation results show the effectiveness of UPFC to control the real and reactive powers. It is found that there is an improvement in the real and reactive powers through the transmission line when UPFC is introduced. The UPFC system has the advantages like reduce maintenance and ability to control real and reactive powers.

IV. REFERENCES

- [1] vibhor gupta , “Study and effects of UPFC and its control system for power flow control and voltage injection in power a power system”, International journal of engineering science and technology vol.2(7),2010,2558-2566
- [2] Hingorani, N.g., “High power Electronics and Flexible AC Transmission System”, IEEE Power Eng. REV., july 1988.
- [3] M. Noroozian, L. Angquist, M. Ghandhari, G. Andersson, “Use of UPFC for optimal power flow”, IEEE Transactions on Power Delivery, vol. 12,No.4, october 1997.
- [4] Phasor Model of UPFC control, MATLAB v 7.6, „help“-UPFC power flow control .
- [5] Control Block of UPFC - M. Toufan, U.D. Annakkage, “Simulation of The Unified Power Flow Controller performance Using PSCAD/EMTDC,” Electrical Power System Research Vol. 46, 1998, pp 67-75.
- [6] A.J.F.Keri,X. Lombard, A. A. Edris, “Unified Power Flow Controller (UPFC): Modelling and Analysis, IEEE Trans. on Power Delivery, Vol. 14, No. 2, April 1999, pp. 648-654.
- [7] L. Xu and V.G. Agelidis, “Flying Capacitor Multilevel PWM Converter Based UPFC”, IEE Proc. Of Electronic

Power Application,Vol. 149, No. 4, July 2003. Page(s) 304-310.

[8] Narain G. Hingorani, Laszlo Gyugyi, “Understanding FACTS: Concepts and Technology of Flexible AC Transmission Systems,”IEEE Press Marketing, 1999, pp. 297-352, pp. 407-424.

[9] C. D. Schauder, D.M. Hamai, A. Edris, “Operation of the Unified Power Controller (UPFC) under practical constraints”,IEEEtransaction on Power Delivery, vol. 13, No. 2, April 1998.

Author’s Profile:

M.Likhitha Kathyayani, pursuing M-Tech in SBIT she completed her b tech and interested to research work in matlab tool.



Nunavatha Shankar working as an Asst. Professor and HOD of EEE Dpartment in Sujala Bharathi Institute of technology, Ogulapur, Warangal, India. He has completed his M.tech from Ramappa Engineering College, Hanamkonda, Warangal, Telengana, India in the year 2012 specialized in Control Systems and has 3-Years of Teaching Experience. He has completed his B.Tech in EEE from Chistu Jyothi Institute of technology and Sciences (CJITS), Yeshwantapur, Warangal in the year 2009 affiliated to Jawaharlal Nehru Technological University, Hyderabad (JNTUH) . He is interested in the area of Control Systems.