

An Implementation of Fuzzy Logic Controller to Buck-Boost Converter Fed BLDC Motor Drive

MOHAMMED VAZID¹, Y. P. SWAPNA²

¹PG Scholar, Dept of EEE, Vemu Institute of Technology, Chittoor, AP, India.

²Project Guide, Dept of EEE, Vemu Institute of Technology, Chittoor, AP, India.

Abstract: This paper shows another PFC bridgeless (BL) buck–boost converter for brushless direct current (BLDC) engine drive application in low-control applications. A Fuzzy logic execution in adaptable speed control of BLDC engine is done here. A methodology of rate control of the BLDC engine by controlling the dc bus voltage of the voltage source inverter (VSI) is utilized with a solitary voltage sensor. The controller is intended to track varieties of pace references and settles the yield velocity amid burden varieties. The BLDC has a few preferences contrast with the other kind of engines; however the nonlinearity of the BLDC engine drive attributes, in light of the fact that it is hard to handle by utilizing customary relative basic (PI) controller. So as to tackle this fundamental issue, the Fuzzy logic control turns into a suitable control. To give an inborn PFC at supply ac mains a converter based on buck-boost type is intended to work in broken inductor current mode (DICM). The execution of the proposed commute is mimicked in MATLAB/Simulink environment.

Keywords: Fuzzy Logic (FL), Bridgeless (BL) Buck–Boost Converter, Discontinuous Inductor Current Mode (DICM), Power Factor Correction (PFC).

I. INTRODUCTION

Since 1980's a new plan idea of changeless magnet brushless engines has been created. The Changeless magnet brushless engines are ordered into two sorts based upon the back EMF waveform, brushless Air conditioning (BLAC) and brushless DC (BLDC) Engines [1]. BLDC engine has trapezoidal back EMF and semi rectangular current waveform. BLDC engines are quickly getting to be well known in businesses, for example, Appliances, HVAC industry, restorative, electric footing, car, airplanes, military gear, hard plate drive, mechanical computerization gear and instrumentation due to their high effectiveness, high power element, noiseless operation, minimized, dependability and low support [2]. To supplant the capacity of commentators and brushes, the BLDC engine requires an inverter and a position sensor that distinguishes rotor position for legitimate substitution of current. The revolution of the BLDC engine is in light of the criticism of rotor position which is gotten from the corridor sensors. BLDC engine ordinarily employments three lobby sensors for deciding the recompense Grouping. In BLDC engine the force misfortunes are in the stator where warmth can be effectively exchanged through the edge or cooling frameworks are utilized as a part of expansive machines. BLDC engines have numerous focal points over DC engines and prompting engines. A percentage of the favorable circumstances are better speed versus torque qualities, high element reaction, high proficiency, long working life, quiet operation; higher pace ranges [3]. Up to now, more than 80% of the controllers are PI (Relative and

vital) controllers on the grounds that they are effortless and straightforward. The velocity controllers are the routine PI controllers and current controllers are the P controllers to accomplish superior commute. Fuzzy Logic can be considered as scientific hypothesis joining multi-esteemed rationale, likelihood hypothesis, & counterfeit consciousness to recreate the human approach in the arrangement of different issues by utilizing an estimated thinking to relate diverse information sets and to make choices. It has been accounted for that fluffy controllers are more powerful to plant parameter changes than traditional PI or controllers and have better clamor dismissal capacities. This paper presents a BL buck–boost converter-fed BLDC motor drive with variable dc link voltage of VSI for improved power quality at ac mains with reduced components and superior control.

II. PRINCIPLE OF BLDC MOTOR

BLDC engine comprises of the perpetual magnet rotor and an injury stator. The brushless engines are controlled utilizing a three stage inverter. The engine obliges a rotor position sensor for beginning and for giving legitimate compensation arrangement to turn on the force gadgets in the inverter extension. In light of the rotor position, the force gadgets are commutated consecutively every 60 degrees. The electronic compensation takes out the issues connected with the brush and the commutator plan, in particular starting and destroying of the commutator brush course of action, along these lines, making a BLDC engine rougher contrasted with a dc engine.

Fig.1 demonstrates the stator of the BLDC engine and fig.2 shows rotor magnet plans.



Fig.1. BLDC motor stator construction.



Fig.2. BLDC motor Rotor construction.

The brush less dc engine comprise of four fundamental parts Power converter, changeless magnet brushless DC Motor (BLDCM), sensors and control calculation. The force converter changes power from the source to the BLDCM which thus changes over electrical vitality to mechanical vitality. One of the remarkable highlights of the brush less dc engine is the rotor position sensors, in view of the rotor position and order signals which may be a torque charge, voltage summon rate order etc; the control calculations focus the entryway sign to every semiconductor in the force electronic converter. The structure of the control calculations decides the sort of the brush less dc engine of which there are two principle classes voltage source based drives and current source based drives. Both voltage source and current source based commute utilized for perpetual magnet brushless DC machine. The back emf waveform of the engine is demonstrated in the fig. 3. Be that as it may, machine with a non sinusoidal back emf brings about diminishment in the inverter size and lessens misfortunes for the same influence level.

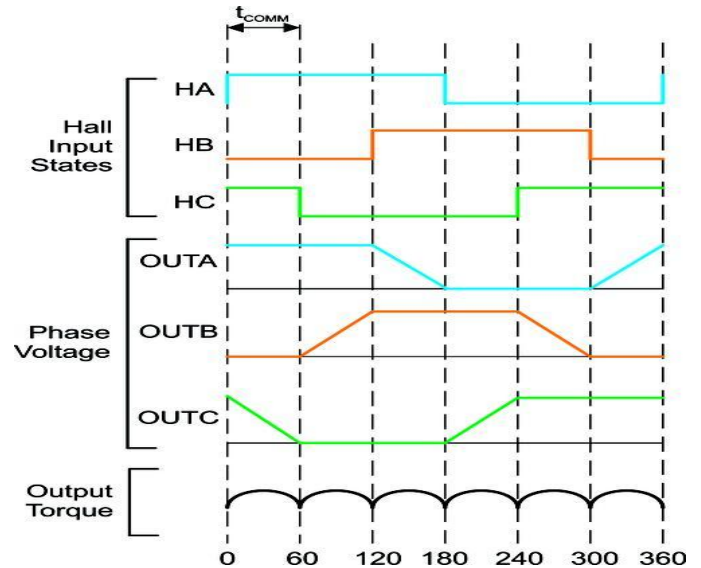

Fig.3. Hall signals & Stator voltages.

III. PROPOSED SYSTEM

The proposed BL buck-boost converter based VSI-fed BLDC motor drive is shown in fig.4. The parameters of the BL buck-boost converter are made such that it operates in discontinuous inductor current mode (DICM) to attain an inherent power factor correction at ac mains. The speed control of BLDC motor is accomplished by the dc link voltage control of VSI using a BL buck-boost converter. This reduces the switching losses in VSI because of the low frequency operation of VSI for the electronic commutation of the BLDC motor.

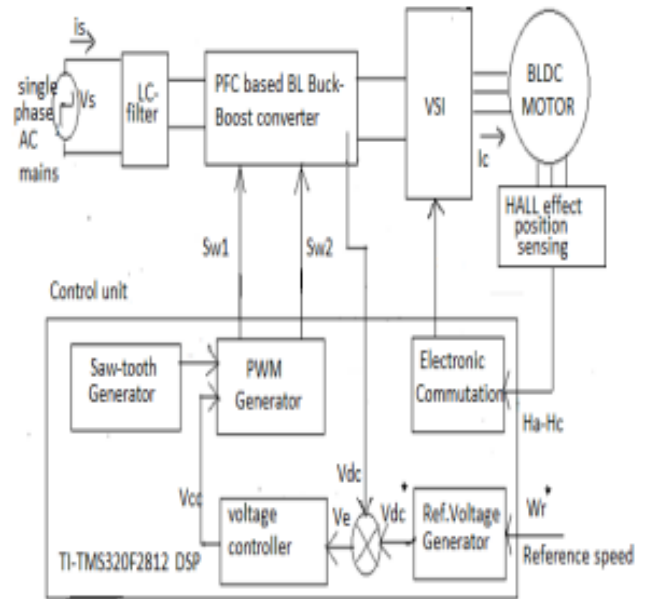

Fig.4. Proposed BLDC motor drive with front-end BL buck-boost converter.

In the proposed arrangement of bridgeless buck-boost converter has the base number of parts and slightest number of conduction gadgets amid every half cycle of supply voltage which administers the decision of BL buck-boost converter

An Implementation of Fuzzy Logic Controller to Buck-Boost Converter Fed BLDC Motor Drive

for this application. The operation of the PFC bridgeless buck-boost converter is ordered into two parts which incorporate the operation amid the positive and negative half cycles of supply voltage and amid the complete exchanging cycle.

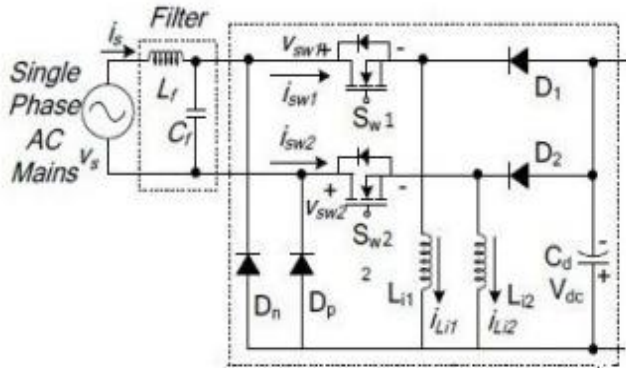

Fig.5 PFC circuit operation.

A. Operation during Positive and Negative Half Cycle of Supply Voltage

In this mode converter switches S_{w1} and S_{w2} are work in positive and negative half cycle of supply voltage individually. Amid positive half cycle switch S_{w1} , inductor L_{i1} and diodes D_1 and D_2 are worked to exchange vitality to DC join capacitor C_d . Thus in negative half cycle of supply voltage switches S_{w2} , inductor L_{i2} and diode D_2 In Irregular Inductor Current Mode(DICM) operation of converter the present in the inductor L_i gets to be irregular for certain term in an exchanging period.

B. Operation during Complete Switching Cycle

In this exchanging cycle there are three methods of operation.

Mode I: In this mode, switch S_{w1} conducts for charging the inductor L_{i1} , thus the inductor current i_{Li1} increments in this mode. Diode D_1 finishes the information side and the DC join capacitor C_d is released by VSI nourished BLDC engine

Mode II: In this method of operation switch S_{w1} is killed furthermore, the put away vitality from the inductor L_{i1} is exchanged to DC join capacitor C_d till the inductor is completely released furthermore; current in the inductor is completely lessened to zero.

Mode III: In this method of operation inductor L_{i1} work in intermittent conduction mode and diodes and switch are in off condition. As of now DC join capacitor C_d begins releasing. This operation can be proceeding up to switch S_{w1} is turned on once more.

IV. PROPOSED FUZZY LOGIC CONTROLLER

The control framework is in light of fuzzy logic. FL controller is a one sort non straight controller and programmed. This kind of the control drawing closer the human thinking that makes the utilization of the acknowledgement, vulnerability, imprecision and fluffiness in the choice making procedure, figures out how to offer an exceptionally tasteful execution, without the need of a definite numerical model of the framework, just by fusing the

specialists' learning into the fluffy. Fig 6 demonstrates the FL controller piece outline. This fluffy rationale control framework is in view of the MAMDHANI fluffy model. This framework comprises of four principle parts. To begin with, by utilizing the info enrollment capacities, inputs are fuzzified then in view of standard bases and the inferencing framework, yields are delivered lastly the fluffy yields are defuzzified and they are connected to the principle control framework.

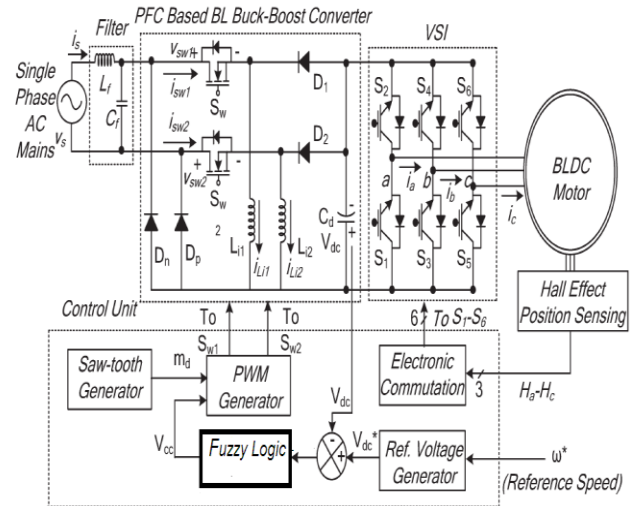

Fig.6.Extension circuit diagram DC-DC converter & BLDC motor with fuzzy controller.

Error of inputs from their references and error deviations in any time interval are chosen as MATLAB as shown in Fig.7. The output of fuzzy controller is the value that should be added to the prior output to produce new reference output as shown in Figs.8 to 11.

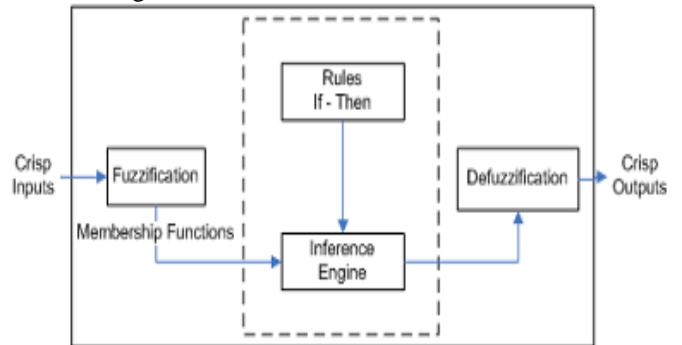

Fig.7. Block Diagram of fuzzy logic controller.

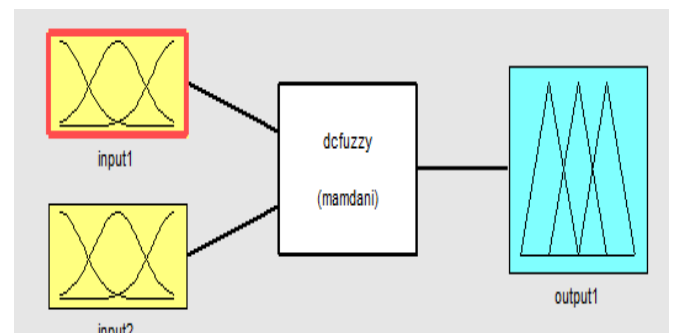

Fig.8. selection of input and output variables.

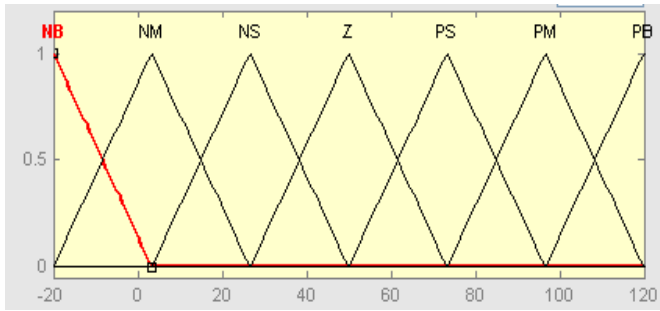

Fig.9. Input1 membership function.

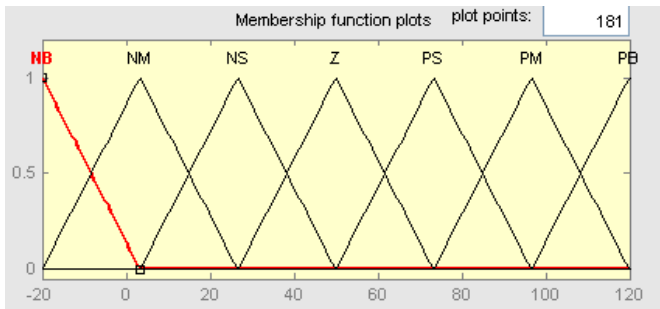

Fig.10. Input 2 membership function.

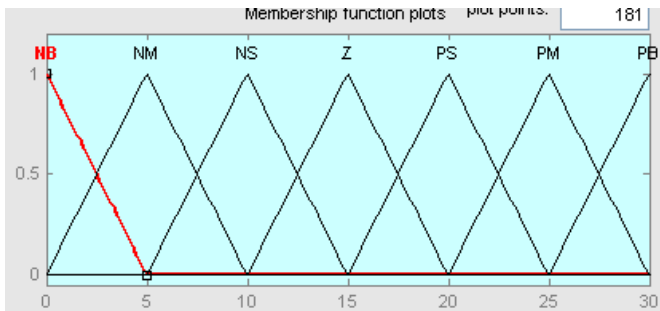

Fig.11. Output membership function.

V. SIMULATION RESULTS

The below fig.12 shows the simulation diagrams of this system.

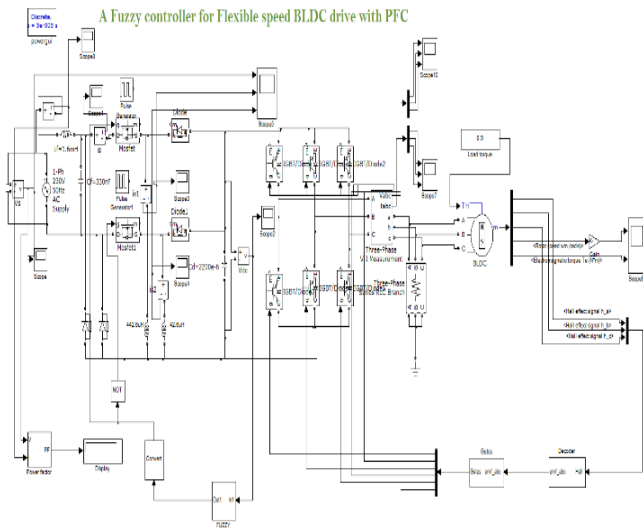

Fig.12. Simulation circuit diagram.

The performance of the proposed BLDC motor drive is simulated in MATLAB/Simulink environment using the Sim power-System toolbox. The performance evaluation of the proposed drive is categorized in terms of the performance of the BLDC motor and BL buck–boost converter and the achieved power quality indices obtained at ac mains. The parameters associated with the BLDC motor such as speed (N), electromagnetic torque (Te), and stator current (ia) are analyzed for the proper functioning of the BLDC motor. Parameters such as supply voltage (Vs), supply current (is), dc link voltage (Vdc), inductor’s currents (iLi1, iLi2), switch voltages (Vsw1, Vsw2), and switch currents (isw1, isw2) of the PFC BL buck–boost converter are evaluated to demonstrate its proper functioning.

Parameters Data Sheet:

- AC Supply =1-ph, 240V, 50Hz
- Filter parameters, Lf=1.6mH, Cf=330nF
- L1=L2=443.7uH
- DC link capacitance, Cdc=2200uF

BLDC Motor Parameters:

- No. Of Poles P=4
- Inertia=0.00062Kg.m^2
- Friction factor=0.0003035 N.m.s
- Stator phase resistance, Rs=14.58 Ohm.
- Stator phase inductance, Ls=25.7mH
- Voltage constant Kv=51.83V (peak)/krpm
- Torque constant, Kt=0.49502 N-m/A (peak)

Waveforms: Waveforms is as shown in Figs.13 to 18.



Fig.13. Input supply voltage.

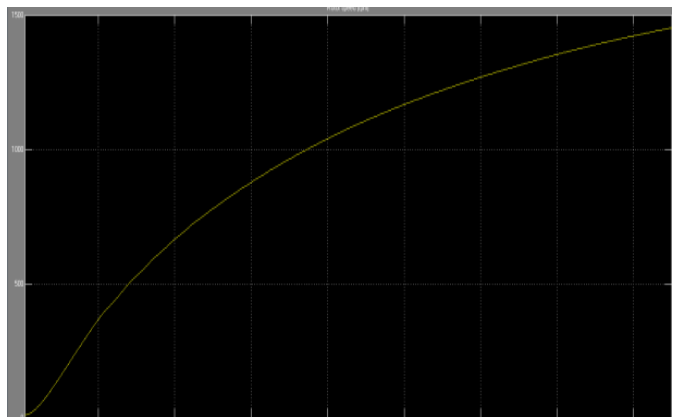

Fig.14. Speed.

An Implementation of Fuzzy Logic Controller to Buck-Boost Converter Fed BLDC Motor Drive

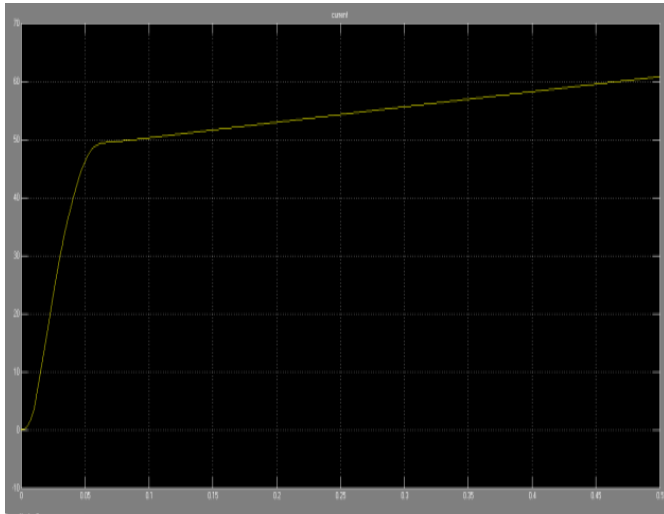

Fig.15. DC Link Voltage.

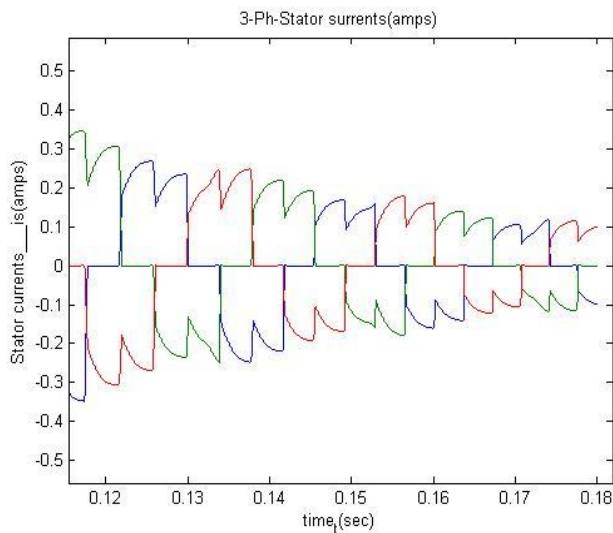

Fig.16. Three Phase Stator Currents.

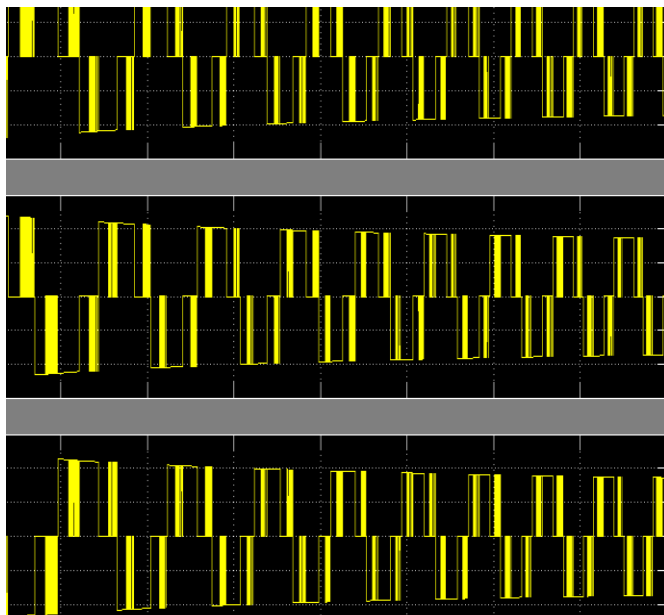

Fig.17. Three Phase stator Input Voltage.

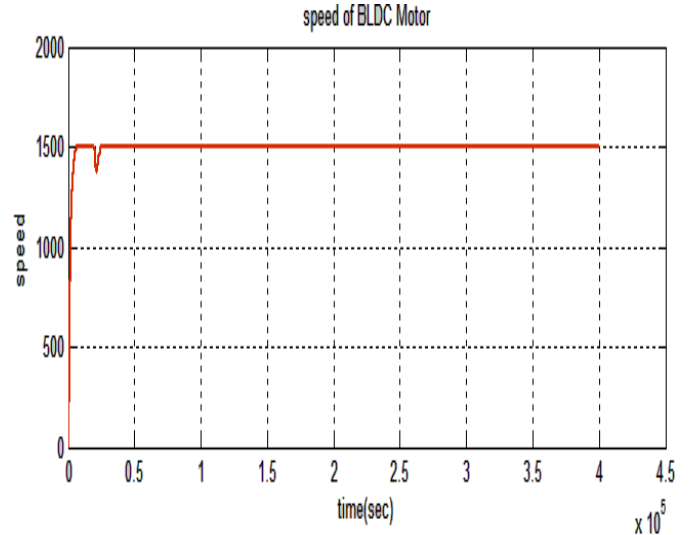

Fig.18. Source side Power factor=0.9975.

VI. CONCLUSION

The dynamic characteristics of the brushless DC motor such as speed, torque, current and voltage of the inverter components are observed and analyzed using the developed MATLAB model. Proposed fuzzy logic controller system has a good adaptability and strong robustness whenever the system is disturbed. The simulation model which is implemented in a modular manner under MATLAB environment allows dynamic characteristics such as phase currents, rotor speed, and mechanical torque to be effectively considered.

VII. REFERENCES

- [1] G. Sakhthival, T.S. Anandhi and S.P. Natarajan. 2010. Real time implementation of DSP based Fuzzy logic controller for Speed control of BLDC motor. *International Journal of Computer Applications* (0975- 8887). 10(8).
- [2] K. Naga Sujatha, K. Vaisakh and Anand. G. 2010. Artificial Intelligence based speed control of brushless DC motor. *IEEE 978-1-4244-6551-4/10*.
- [3] 2003. AN885 - Brushless DC (BLDC) Motor Fundamentals. Microchip Technology Inc.
- [4] R. Akkaya, A.A. Kulaksız, and O Aydogdu, DSP implementation of a PV system with GA-MLP-NN based MPPT controller supplying BLDC motor drive, *Energy Conv. and Management* 48, 210-218, 2007.
- [5]. P. Pillay and R. Krishnan, Modeling, simulation, and analysis of permanent-magnet motor drives, part II: the brushless DC motor drive, *IEEE Trans. on Industry Applications* 25, 274–279, 1989.
- [6]. P.D. Evans and D. Brown, Simulation of brushless DC drives, *Proc. of the IEE* 137, 299–308, 1990.
- [7]. R. Carlson, M. Lajoie-Mazenc, and C.D.S. Fagundes, Analysis of torque ripple due to phase commutation in brushless DC machines, *IEEE Trans. on Industry Applications* 28, 632–638, 1992.
- [8]. S.K. Safi, P.P. Acarnley, and A.G. Jack, Analysis and simulation of the high-speed torque performance of brushless DC motor drives, *Proc. of the IEE* 142, 191–200, 1995.

[9]. J. Figueroa, C. Brocart, J. Cros, and P. Viarouge, Simplified simulation methods for polyphase brushless DC motors, *Mathematics and Computers in Simulation* 63, 209–224, 2003.

[10]. C.W. Hung; C.T. Lin, and C.W. Liu, An Efficient Simulation Technique for the Variable Sampling Effect of BLDC Motor Applications, *IECON 2007*, pp. 1175– 1179, 2007.

Author's Profile:



Mr. Mohammed Vazid was born in Andhra Pradesh, India. He received the B.Tech (Electrical and Electronics Engineering) degree from JNTU University, India in 2013 and the M.Tech (Power Electronics & Electrical Drives) pursuing from same University. In 2016 (Nove), He

Joined the Dept. Electrical and Electronics Engineering, in Vemu Institute of Technology, as a PG-Student, Email: vazidshaik.11@gmail.com.



Ms. Y.P Swapna was born in Andhra Pradesh, India. She received the B.Tech (Electrical and Electronics Engineering) degree from JNTU Ananatapur, Tirupathi, India in 2007 and the M.Tech (Electrical Power Engineering) from JNTU Ananthapur, in 2009. She is working as an

Associate Professor in, has experienced and joins in Dept. Electrical and Electronics Engineering, in Vemu Institute of Technology).