



Development of Application Program for PLC and SCADA Oil Pipeline Automation

R. MUKESH¹, DR. M.KAMARAJU², NOOR AHMED³

¹PG Scholar, Dept of DECS, Gudlavalleru Engineering College, Gudlavalleru, AP, India, E-mail: repallemukesh@gmail.com.

²Prof & HOD, Dept of ECE, Gudlavalleru Engineering College, Gudlavalleru, AP, India, E-mail: madduraju@yahoo.com.

³DGM, Dept of CNID, Electronic Corporation of India Limited, Hyderabad, AP, India, E-mail: noor_ahmed@ecil.co.in.

Abstract: In any control system Programmable Logic Controller (PLC) plays a major role. In an automated system, the PLC is commonly regarded as the heart of the control system. With a control application program (stored within the PLC memory) in execution, the PLC constantly monitors the state of the system through the field input device's feedback signal. It will then base on the program logic to determine the course of action to be carried out at the field output devices. The PLC may be used to control a simple and repetitive task, or a few of them may be interconnected together with other host controllers or host computers through a sort of communication network, in order to integrate the control of a complex process. The soft wiring advantage provided by programmable controllers is tremendous. In fact, it is one of the most important features of PLCs. Soft wiring makes changes in the control system easy and cheap. If you want a device in a PLC system to behave differently or to control a different process element, all you have to do is change the control program. In a traditional system, making this type of change would involve physically changing the wiring between the devices, a costly and time-consuming endeavour. In this paper "Development of Application Program For PLC and SCADA Oil Pipeline Automation", logic programs will be developed to operate remotely Motor operated valves, pressure control valves, variable frequency drives for automatic operation and control of the cross country pipeline.

Keywords: PLC, SCADA, RTU, Communications, Data Management, HMI, Alarm, Security, Measurement, Flow Meters, Flow Computer, Station Control, Meter Station, Tank.

I. INTRODUCTION

This chapter summarizes pipeline system automation and control with an emphasis on a Supervisory Control and Data Acquisition (SCADA) system together with its associated field instrumentation and station automation. The goal is to introduce the concepts of pipeline automation and control rather than to provide expert knowledge. The key role of pipeline companies is to transport their products from various product sources to designated markets safely and in the most economical manner possible. During the past few decades, pipeline systems have grown in size and complexity, driven by business requirements consolidating pipelines in fewer entities and by more interconnections between pipeline systems. At the same time, environmental concerns and safety issues require more sophisticated monitoring and control system.

Therefore, the pipeline operation and commercial transactions have become more complicated. Also, shippers and producers demand accurate information expediently, particularly information on custody transfer and transportation data. In short, the business cycle is becoming shorter, the number of users are increasing, different users require different information, users are spread-out

geographically, and accurate information has to be exchanged at a much faster rate. In the past, a SCADA system was used primarily to monitor and control compressor/pump and meter stations. The SCADA system users were typically the pipeline dispatchers, system engineers, local operators, and maintenance staff. They were located at one or more dispatching centres and local operation centres. Due to the development of communication and computer technologies, potential users of the automation system have increased significantly, covering both internal and external customers. Now, the customers include not only the typical users but also internal and external users.

In order to meet these requirements, centralized pipeline monitoring and system automation is necessary. Such a centralized system allows the pipeline company to manage transportation services effectively and to improve its operating efficiency and profitability. At the core of the centralized system is a SCADA system. A centralized SCADA system offers numerous benefits. It enables the pipeline operators to perform operating tasks remotely by providing accurate and real-time information, assists them to monitor and control product movements accurately, and allows for safe operation of the pipeline system including

pump or compressor stations. In addition, the SCADA system can facilitate efficient operation and satisfies the pipeline customers by providing reliable and timely information. All SCADA systems require field instrumentation that provides various measurements.

The key measuring devices are flow meters, pressure and temperature transducers, and a densitometer or chromatograph. These measurements are uploaded to the host SCADA through remote terminal units (RTUs). This chapter addresses the instrumentation issues essential to pipeline system operations. A typical SCADA system consists of various sub-systems, which are monitoring and controlling local stations. It is connected to remote local stations via a communication network. A local control system such as a Programmable Logic Controller (PLC) controls the main systems such as a compressor/pump and/or meter station. These control and monitoring systems have appropriate measurement devices. This chapter also discusses the compressor/pump stations, meter station and tank farm control. Compressor and pump stations are the most complex facilities in pipeline systems. In order to operate such complex installations, monitoring and controlling equipment's are a necessity. Meter stations and tank farms play an important role in pipeline operations, because custody transfer and billings are based on volume measurements.

II. SUPERVISORY CONTROL AND DATA ACQUISITION (SCADA) SYSTEM

SCADA is an acronym of Supervisory Control and Data Acquisition. A SCADA system is a computer-based data acquisition system (often referred to as a SCADA host) designed to gather operating data from an array of geographically remote field locations, and to transmit this data via communication links to one or more control centre location(s) for control, display and reporting. Operators at one or more control centers monitor this data. They may then issue commands of a supervisory nature to the remote locations in response to the incoming data. Additionally, software programs implemented within the SCADA host can provide for specific responses to changes in field conditions, by reporting such changes or automatically sending commands to remote field locations. It must be noted that a SCADA system is designed to assist pipeline operators in the operation of the pipeline system using real-time and historical information, but not to provide a closed-loop control function.

III. HISTORY

SCADA systems were first developed for use in the electrical industry for control of high voltage transmission systems. Electrical systems have special requirements for response speed and reliability that have driven the development of SCADA system capabilities. The first field-control systems in the pipeline industry were based upon pneumatics and confined to a particular plant facility with no remote control or centralized control. The first step towards centralized automation was the introduction of remote

telemetry. This allowed a central location to monitor key pipeline parameters on a remote meter. Since there was no remote control, operators at control centers would contact local operators by telephone or radio to make any adjustments or to start or stop equipment such as pumps or compressors. The next step in the evolution of control systems was the development of simple local logic controllers that used electromechanical relays to implement the logic. This ensured proper sequencing of equipment and prevented the operation of equipment if a key component was not operational. It also made it possible to issue commands from the dispatching centre and receive equipment status and key analog data at the dispatching centre. This was the first SCADA system. With the advent of the integrated circuit, these systems no longer required electromechanical relays and the capability of the system increased.

The development of the mini-computers in the 1970's provided a huge kick-start to many of the automation systems seen today. Remote control and monitoring of pipelines were made technically and economically feasible. These systems were now able to provide storage as well as display status and analogue readings on a CRT screen. The cornerstone components of a modern SCADA system were now in place: local control and data gathering, centralized master unit, central storage on disk and display on computer screens. The personal computer in the 1980's, may prove to have been the single biggest advance in the development of pipeline automation technology. In parallel with the development of the personal computer, the 1980's saw the introduction of local and wide area networks and thus the potential for more advanced communication. Systems that were once considered prohibitively expensive for many business operations had now become affordable.

During the 1990's information technology firmly established itself in almost all areas of the pipeline industry. We have seen significant advancements in automation systems in the pipeline industry as evidenced by electronic measurement systems, controller devices, logic controllers such as Programmable Logic Controllers (PLCs) and remote terminal units (RTUs), and SCADA system hosts. Located at one or more strategic control centres, SCADA provides operations and management personnel with full access to current and historical data through computer terminals that feature a full set of graphic displays, reports, and trends. Along with the computer and communication network technologies, we have been witnessing great advancements since the late 1990's and 2000's in internet technology and its applications to the pipeline industry. Even though the pipeline industry has not yet fully utilized the potential of internet technology, closer integration between the field and office information systems has been accelerating and internet-enabled applications are proliferating.

IV. SCADA SYSTEM ARCHITECTURE

A SCADA host or "master" is a collection of computer equipment and software located at the control centre and used to centrally monitor and control the activity of the SCADA

Development of Application Program for PLC and SCADA Oil Pipeline Automation

network, receive and store data from field devices and send commands to the field. The architecture of SCADA systems can vary from a relatively simple configuration of a computer and modems to a complicated network of equipment. All SCADA systems will incorporate the following key hardware and software capabilities:

1. Ability to interface with field devices and facilities for control and/or monitoring, usually through a remote terminal unit (RTU)
2. Provision of a communication network capable of two-way communication between the RTU and the control centre
3. Ability to process all incoming data and enable outgoing commands through a collection of equipment and software called the SCADA host
4. Support to pipeline operations through application software such as leak detection, inventory applications and training
5. Ability to interface to corporate systems
6. Provision of some business applications such as meter ticketing, nomination management, etc.

Modern computing environment encourages client/server architecture, because it allows client functions to be flexible while enabling server functions to be made robust. Typically, the human-machine interface works as a client and SCADA and application computers as servers in a client/server architecture. The SCADA servers access all RTUs, PLCs and other field devices through a communication server by connecting the communication devices to the host SCADA computers. The real-time and historical databases reside in the SCADA server computers. There are three basic tiers in a SCADA system as shown in Figure 1, namely: field, control room, and corporate. The field to SCADA connection is some form of a telecommunications network, and the connection between SCADA host and the corporate or enterprise environment is made with a Wide Area Network (WAN). A backup control system located at an offsite may be connected via a WAN to the main control system.

The network is normally an internal private network. However, there are now SCADA systems that utilize secure connections to the Internet that replaces the private network. Web-based SCADA systems are ideal for remote unattended applications. They are suitable to pipeline systems or remote locations where centralized computing or control requirements are not intense and the primary function is remote data gathering. It can be economically installed on locations where it is expensive to install a communication line or a traditional SCADA installation cannot be economically justified. A typical SCADA hardware architecture is shown in Figure 2. The host computer equipment generally consists of:

- One or more SCADA servers
- Network component(s) (routers/hubs)
- Storage Server(s) for storage of historical data
- Application server(s)
- Communication server

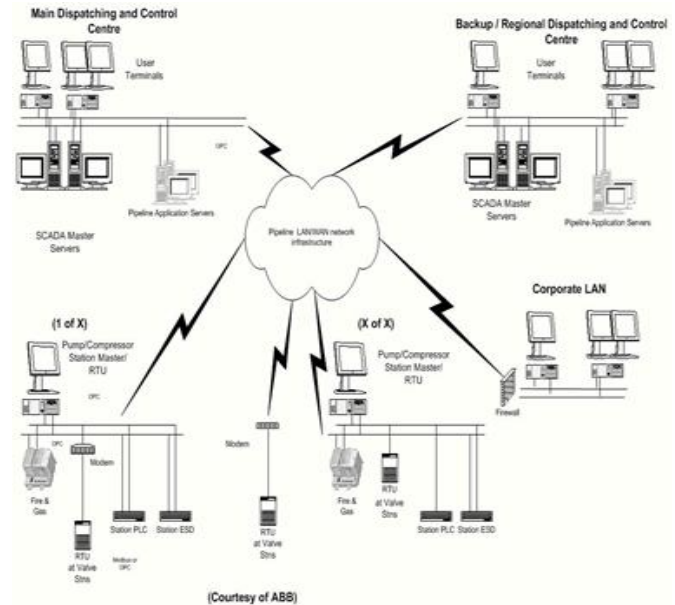

Fig1. Typical SCADA Architecture.

In today's networked environment, standard workstations or desktop computers are configured to be an operator workstation or other system console with a graphical user interface. In a distributed process environment, host functionality can be split among multiple computers in single or multiple locations. The requirements for redundancy and reliability will dictate the final configuration and variations to this basic architecture. The distributed nature of a networked SCADA host allows for the distribution of functionality between servers. This allows routine maintenance to occur with minimal impact on core SCADA applications.

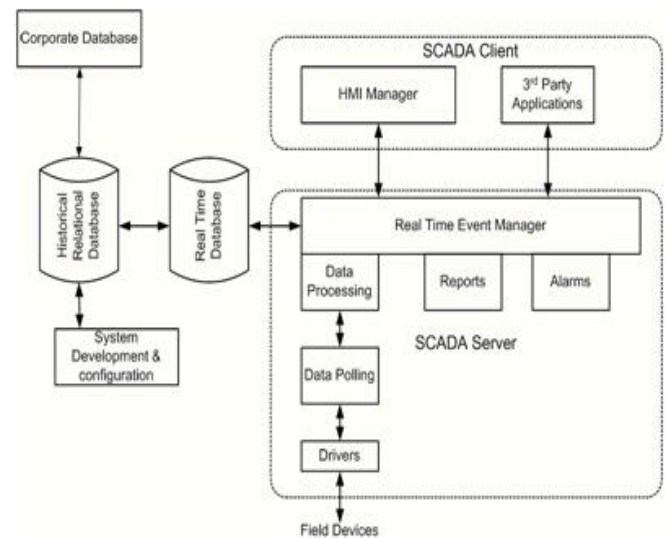

Fig2. High-Level SCADA Host Software Architecture.

The critical SCADA functionality can reside on a primary and a backup server in two general modes. These are "hot standby" or "cold standby":

- "Hot standby" means that two servers are continuously operating in parallel and the operating system will

automatically switch to the functioning server in the event of a failure.

- “Cold Standby” means that in the event of a failure of the primary server, the idle server takes over operation. This will result in a delay and some data loss. For these reasons, the general approach in a modern networked SCADA host is to provide hot standby servers to critical functions.

Other considerations regarding the infrastructure to support the SCADA host system include power supplies, heating and ventilation, physical security, and system maintenance. SCADA host software architecture is different for every product. However, they all have the following key components as indicated in Figure 2.

- Operating system such as UNIX, Windows or Linux
- Relational database for historical data management, interfacing with corporate databases
- Real Time Database (RTDB) for processing real time data quickly
- Real time event manager, which is the core of the SCADA server
- HMI manager for user interfaces

In addition, utilities, development software and applications are required for system development, configuration, and maintenance. The SCADA server will manage the polling of data, processing of that data and the passing of it to the RTDB. The server will make data available to the presentation layer consisting of the HMI Manager and interfaces to other applications, as well as process control and data requests. The administration and configuration process will have all of the tools required initially to set up the database, RTUs and displays as well as system administration tools for ongoing maintenance of the system. The capability to write custom internal applications and scripts will be handled by this software.

V. INTERFACING

Remote terminal units (RTUs) collect the measured values and send them to the host SCADA system through various communication networks. Modems are used for the connection between a RTU and the SCADA network or connection directly to the RTU where it is not feasible to have a high-speed network. A modem is an electronic device that encodes digital data on to an analog carrier signal and decodes modulated signals. This enables computers' digital data to be carried over analog networks, such as cable television lines and the conventional telephone network. For proper data communication, a formal set of rules, conventions, and data structure, called a protocol, is required. It governs how computers and other network devices exchange information over a network. In other words, a protocol is a standard procedure and format that two data communication devices must understand, accept, and use to be able to exchange data with each other. The Open Systems Interconnection (OSI) model is a reference model developed by ISO (International Organization for Standardization) in 1984, as a conceptual framework of standards for

communication in a network across different equipment and applications by different vendors. A wide variety of network protocols exist, which are defined by worldwide standards organizations and technology vendors over years of technology evolution and development.

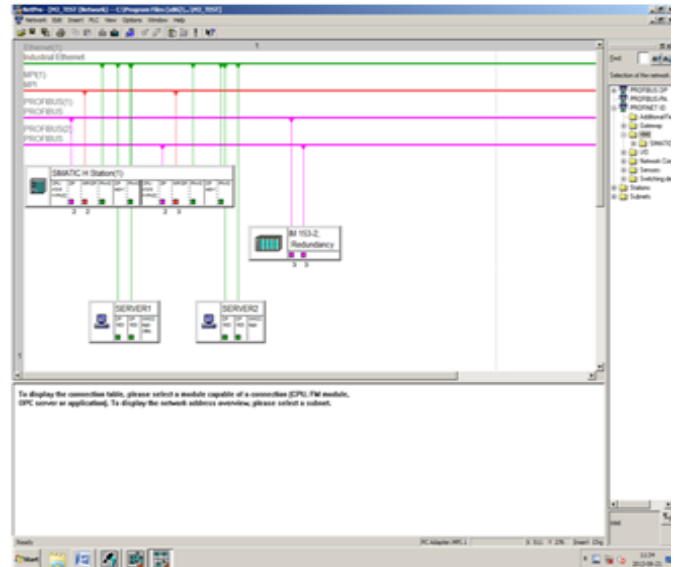

Fig3. Sample Hardware Diagnostics Screen.

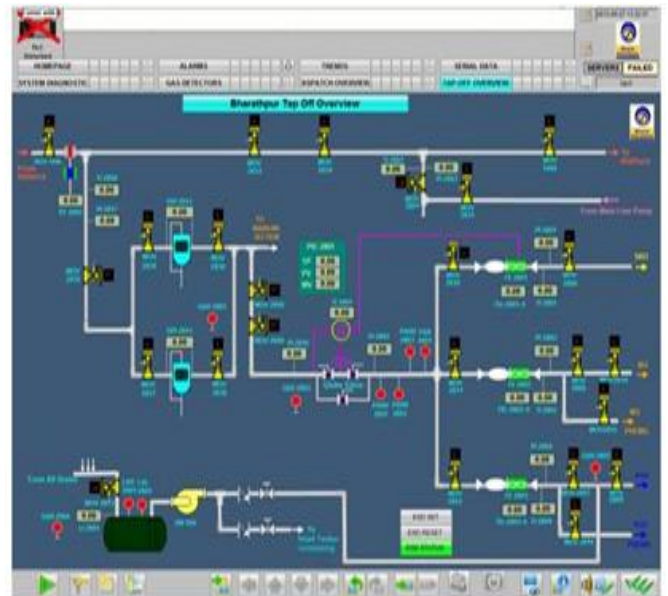

Fig4. Sample Project Screen of Oil Pipeline.

One of the most popular network protocol suites is TCP/IP, which is the heart of Internetworking communications and uses a similar but different model to that of OSI (TCP/IP predates the OSI model). Figure 3 and 4 shows the sample hardware diagnostics screen and sample project screen of oil pipeline. A SCADA system will usually incorporate a local area network (LAN) and one or more wide-area networks (WANs). Current SCADA systems use WAN protocols such as the TCP/IP protocol suite. Not only does this facilitate the use of standard third party equipment but more importantly it allows for the possibility to distribute

Development of Application Program for PLC and SCADA Oil Pipeline Automation

SCADA functionality across a WAN and not just a LAN. In some WAN distributed systems, pipeline controls are not assigned to a single central location. Instead, control operations can be switched or shared between numerous control centers. The SCADA network model as shown in Figure 1 requires some form of communication media to implement the WAN connection between the SCADA host and remote locations. The most popular media include metallic telephone line, fibre optic cable, radio, and satellite. Ultimately the choice of which media to use to implement a connection to a remote site will be based on cost, availability of a particular medium and technical factors such as reliability, bandwidth, geography, etc. The process of the SCADA host communicating with a number of RTUs is called "polling." Three basic types of polling regimes are:

- Polled Only - In this arrangement, the SCADA host will sequentially initiate communication with each RTU in sequence on a fixed schedule. For a system with a large number of points to be updated at the SCADA host, this may take some time and therefore there will be some time lag between the sample time for the first data point and the last.
- Report by Exception (RBE) - In this scheme, a local history of each data point is saved and the RTU will only send back those points that have changed more than a pre-set value since the last poll. The pre-set value is called a dead band. This reduces the amount of data traffic on the network
- Unsolicited RBE - In this case, the host does not poll on a regular basis, but each RTU "pushes" data back to the host when it has updated data to send. This can reduce data traffic even more than the polled RBE.

VI. FEATURES OF WINCC

- Modern 32 bit operating system
 - Multitasking
 - Safe for industrial applications
 - Fast
- Supports data exchange with other Windows application.
- Uses the database MS SQL Server 2005
- ANSI C, VBA, VBS programming interfaces in the graphic designer.

VII. APPLICATION POSSIBILITIES OF WINCC

- Energy management control systems for buildings (ventilation ,air conditioning)
- Materials handling technology
- Mechanical Engineering
- Water resources and waste water management
- Steel Industry
- Iron producing Industry
- Foundries
- Cold rolling mills
- Steel casting industry
- Chemical industry

- Pulp , paper, and corrugated cardboard production
- Breweries, malt factories, and soft drink production
- Food stuffs and luxury food industry
- Milk processing industry
- Sugar industry etc.

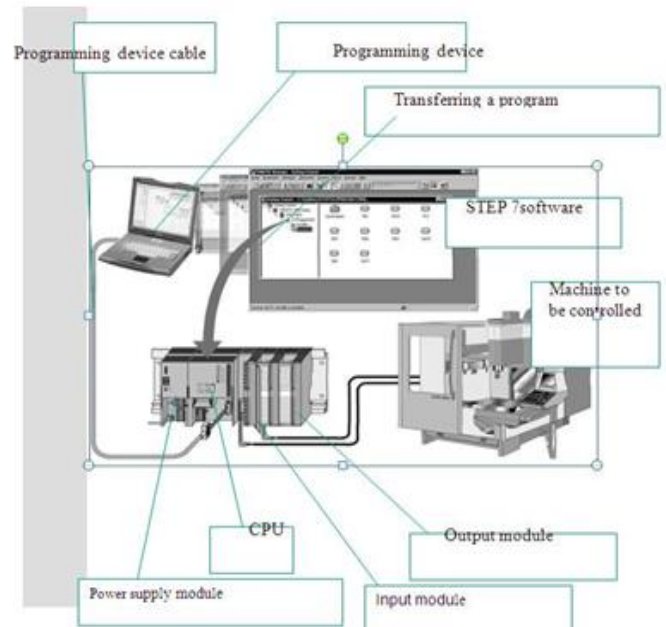

Fig 5. Typical SCADA (WINCC) Architecture.

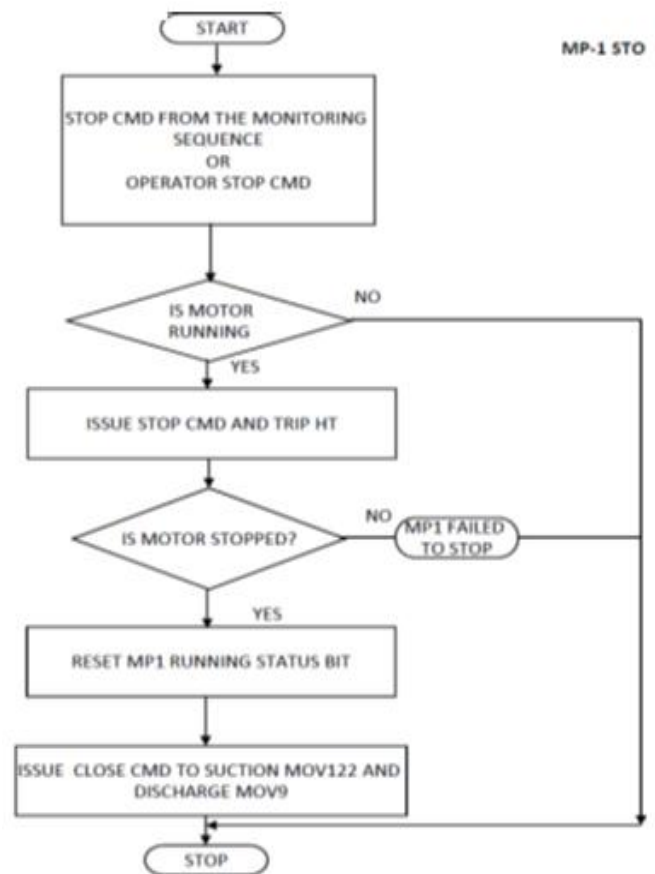

Fig6. Sample Flow Charts for Main Pump Stop Sequence.

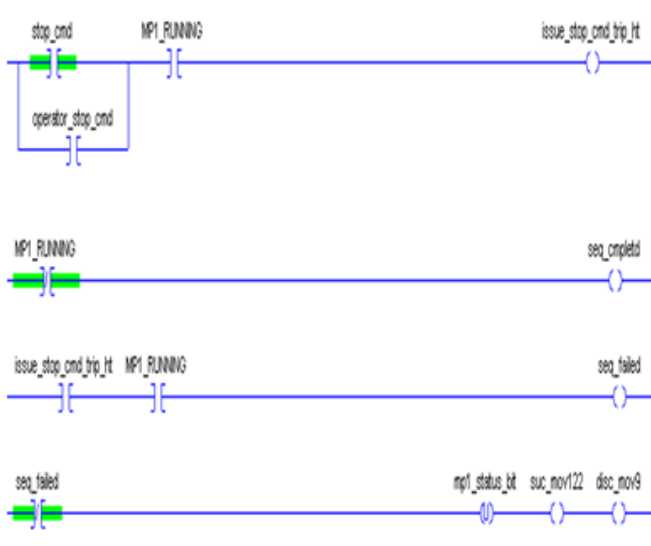

Fig7. Sample Ladder Diagram for Main Pump Stop Sequence.

The above figures 5, 6 and 7 show the Typical Architecture of SCADA, Sample flow charts for Main Pump Stop Sequence and Sample Ladder Diagram for Main Pump Stop Sequence.

VIII. STEP 7 HARDWARE DIAGNOSTICS

The standard package programming software is used for configuring hardware, establishing communications, programming, testing and it supports you in all phases of the creation process of an automation task, such as:

- Setting up and managing projects
- Configuring and assigning parameters to hardware and communications
- Managing symbols
- Creating programs, for example, for S7 programmable controllers
- Downloading programs to programmable controllers
- Testing the automation system
- Diagnosing plant failures

The soft wiring advantage provided by programmable controllers is tremendous. In fact, it is one of the most important features of PLCs. Soft wiring makes changes in the control system easy and cheap. If you want a device in a PLC system to behave differently or to control a different process element, all you have to do is change the control program. In a traditional system, making this type of change would involve physically changing the wiring between the devices, a costly and time-consuming Endeavour.

IX. ADVANTAGES

The observation consistency (site – to –site and day – to –night)

- Objective & uniform measurements
- High frequency of data provision
- Higher accuracy & quality of data
- Better timeliness and data availability
- More frequent special observations

X. CONCLUSION

The application programs for Siemens (s7-400) plc. In pipeline automation is successfully completed and running in field.

XI. REFERENCES

- [1] GEC Automation Projects, 2870 Avondale Mil Rd., Macon, GA 31206, USA.
- [2] General Electric, Automation Controls Dept., Box 8106, Charlottesville, VA 22906, USA.
- [3] General Numeric, 390 Kent Ave., Elk Grove Village, IL 60007, USA.
- [4] Giddings & Lewis, Electrical Division, 666 South Military Rd., Found du Lac WI 54935-7258, USA.
- [5] Gould Inc., Programmable Control Division, PO Box 3083, Andover, MA 01810, USA.
- [6] Guardian/Hitachi, 1550 W, Carroll Ave., Chicago, IL 60607, USA.
- [7] Honeywell, IPC Division, 435 West Philadelphia St., York, PA 17404, USA.
- [8] Webb, J.W., R.A., “Programmable Logic Controllers, Principles & Applications”, Prentice Hall, 1995.