

Design and Implementation of Real Time Patient's Health Monitoring System Based on ARM-7 Processor

K. SAIKUMAR¹, VASEEM AHMED QURESHI²

¹PG Scholar, Dept of ECE, CMR Engineering College, Hyderabad, India.

²Assoc Prof, Dept of ECE, CMR Engineering College, Hyderabad, India.

Abstract: Now a day's healthcare industry is to provide better to people anytime and anywhere in the world in a more economic and patient friendly manner. In the present paper the physiological parameters such as a ECG, Pulse rate and Mems, Temperature are obtained. Processed using a ARM7 LPC2148 processor and displayed in the MATLAB graphical user interface. If any vital parameter goes out of a normal range then alert SMS will be sent to a Doctor Section. This system is utilizing WIFI panel software. Incorporating technologies such that a GPRS, Wi-Fi to these systems allows the wireless transmission to health or control centers. These systems must be embedded in low cost small devices with in a low power consumption should have an interface that is usable by the patient.

Keywords: Pulse Rate, Temperature, Mems, ECG, ARM, Zigbee, GSM, Wi-Fi, Matlab-PC.

I. INTRODUCTION

The electronics technology has entered almost in all Aspects of day-to-day life, and the medical field is not exception for that. The need for well-equipped hospitals and diagnostic centers increasing day by day as the people are becoming more conscious about their health problems. In biomedical fields special units are used, such as intensive care unit. All of these units are designed to offer the advantage of the low Nurse-Patient ratio and concentration of the equipment and the resources needed; to take care of critically ill or seriously injured units. In bio-medical, in chemicals, sugar, many parameters are to be monitored. Depending upon the requirement the number of channels, the number of type in sensor is decided. In many of the Hospitals, in night shifts we find one or two nurses are carrying 50 to 80 patients at the same time. Most of the hospitals have medical surgical emergency teams that rush to the scene of situation that would be life threatening. it has become feasible to design to home based vital sign monitoring system to display, record and transmit signals from human Body to any other location.

The computer based Signal Acquisition, processing and analysis system using MATLAB to display ECG Waveform and filtering tool for ECG waveform. This paper discusses the aspects of acquisition of physiological Parameters like ECG Temperature, Pulse rate, and Mems, pre-processing them and displaying them in a graphical user interface for being viewed by the doctor and also observes the clinically useful data, Firstly on Doctors computer by using Wi-Fi panel application and secondly which contains web browser to posting in Doctor Computer. This system is expected to monitor patient under critical care more conveniently and accurately for

diagnosing which can be interfaced with computer to monitor the patient's condition sitting in his own office without being physically present near to the patient's bed.

II. HARDWARE DESIGN OF SYSTEM

Micro Controller: This section forms the control unit of the whole project. This section basically consists of a Microcontroller with its associated circuitry like Crystal with capacitors, Reset circuitry, Pull up resistors (if needed) and so on. The Microcontroller forms the heart of the project because it controls the devices being interfaced and communicates with the devices according to the program being written.

ARM-7TDMI: ARM is the abbreviation of Advanced RISC Machines, it is the name of a class of processors, and is the name of a kind technology too. The RISC instruction set, and related decode mechanism are much simpler than those of Complex Instruction Set Computer (CISC) designs.

Liquid-Crystal Display (LCD): It is a flat panel display, electronic visual display that uses the light modulation properties of liquid crystals. Liquid crystals do not emit light directly. LCDs are available to display arbitrary images or fixed images which can be displayed or hidden, digits, and 7-segment displays as in a digital clock. They use the same basic technology, except that arbitrary images are made up of a large number of small pixels, while other displays have larger elements.

III. BLOCK DIAGRAM OF SYSTEMS

A. Transmitter Section (Patient-1):

IV. BOARD HARDWARE RESOURCES FEATURES

A .Pulse Sensor

Pulse sensor is also called as Heart Beat Sensor. This heart beat sensor is designed to give digital output of heart beat when a finger is placed inside it. When the heart detector is working, the top-most LED flashes in unison with each heart beat. This digital output can be connected to microcontroller directly to measure the Beats Per Minute (BPM) rate. It works on the principle of light modulation by blood flow through finger at each pulse.

B .Temperature Sensor

The LM35 is an integrated circuit sensor that can be used to measure temperature with an electrical output proportional to the temperature (in °C) The LM35 - An Integrated Circuit Temperature Sensor You can measure temperature more accurately than a using a thermistor. The sensor circuitry is sealed and not subject to oxidation, etc. The LM35 generates a higher output voltage than thermocouples and may not require that the output voltage be amplified.



Fig4. Pin Diagram of LM35

It has an output voltage that is proportional to the Celsius temperature. The scale factor is .01V/°C The LM35 does not require any external calibration or trimming and maintains an accuracy of +/-0.4 °C at room temperature and +/- 0.8 °C over a range of 0 °C to +100 °C. Another important characteristic of the LM35DZ is that it draws only 60 micro amps from its supply and possesses a low self-heating capability. The sensor self-heating causes less than 0.1 °C .

C. ECG Circuit:

Usually more than 2 electrodes are used and they can be combined into a number of pairs (For example: Left arm (LA), right arm (RA) and left leg (LL) electrodes form the pairs: LA+RA, LA+LL, RA+LL). The output from each pair is known as a lead. Each lead is said to look at the heart from a different angle. Different types of ECGs can be referred to by the number of leads that are recorded, for example 3-lead, 5-lead or 12-lead ECGs (sometimes simply "a 12-lead"). A 12-lead ECG is one in which 12 different electrical signals are recorded at approximately the same time and will often be used as a one-off recording of an ECG, typically printed out as a paper copy. 3- and 5-lead ECGs tend to be monitored continuously and viewed only on the screen of an appropriate monitoring device, for example during an operation or whilst being transported in an ambulance. There may, or may not be any permanent record of a 3- or 5-lead ECG depending on the equipment used.

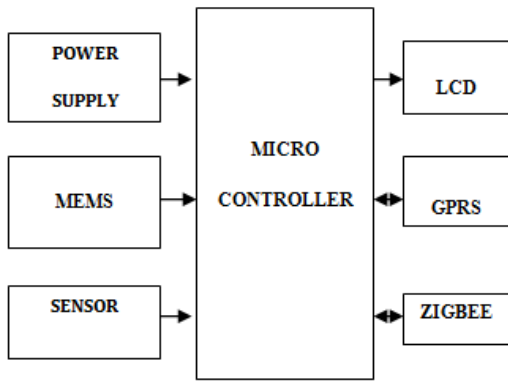

Fig1. Patient-1section.

B. Patient-2 Section:

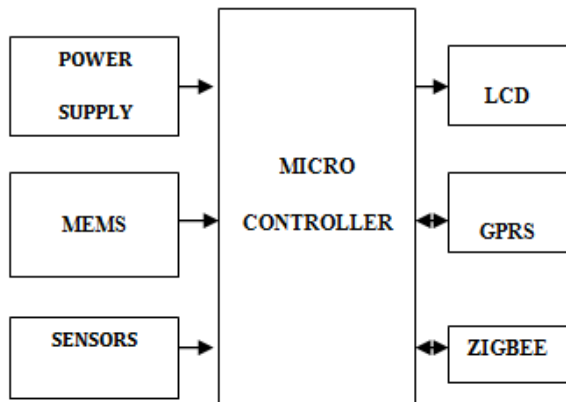

Fig2. Patient-2 section.

C. Receiver Section (Doctor Section):

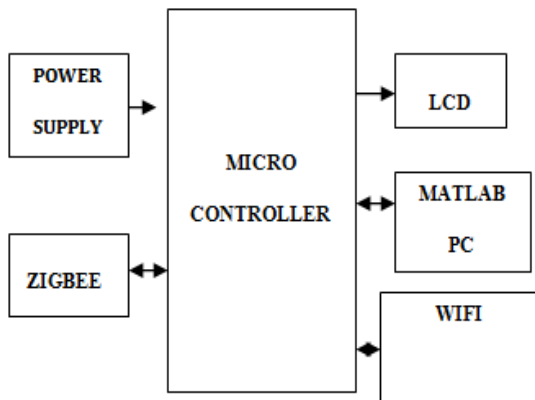

Fig3. Doctor section.

An interactive intelligent healthcare and monitoring system (IIHMS) including body sensor network (BSN) and local sensor network has been presented. The wireless bio-signal acquisition for BSN application is applied to acquire the real human body data via ZigBee network communication. The high integration TX-Baseband processor with ZigBee protocol. In addition, an ARM-based receiver platform with an RF receiver, an analog to digital mixed mode board, ARM-based displayer to demonstrate values.

Design and Implementation of Real Time Patient's Health Monitoring System Based on ARM-7 Processor

It is the best way to measure and diagnose abnormal rhythms of the heart, particularly abnormal rhythms caused by damage to the conductive tissue that carries electrical signals, or abnormal rhythms caused by electrolyte imbalances. In a myocardial infarction (MI), the ECG can identify if the heart muscle has been damaged in specific areas, though not all areas of the heart are covered. The ECG cannot reliably measure the pumping ability of the heart, for which ultrasound-based (echocardiography) or nuclear medicine tests are used. It is possible to be in cardiac arrest a normal ECG signal (a condition known as pulse less electrical activity). The output of an ECG recorder is a graph (or sometimes several graphs, representing each of the leads) with time represented on the x-axis and voltage represented on the y-axis. A dedicated ECG machine would usually print onto graph paper which has a background pattern of 1mm squares (often in red or green), with bold divisions every 5mm in both vertical and horizontal directions.

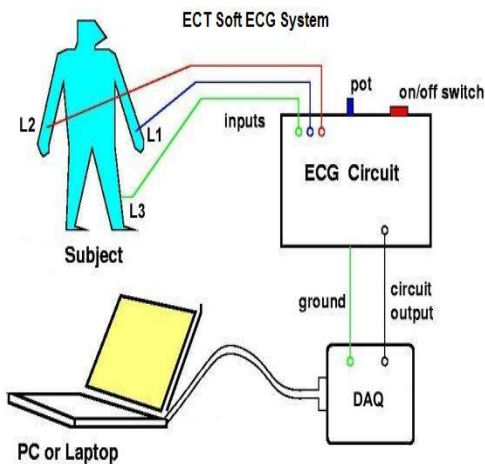

Fig5. ECG data acquisition and processing.

It is possible to change the output of most ECG devices but it is standard to represent each mV on the y axis as 1 cm and each second as 25mm on the x-axis (that is a paper speed of 25mm/s). Faster paper speeds can be used - for example to resolve finer detail in the ECG. At a paper speed of 25 mm/s, one small block of ECG paper translates into 40 ms. Five small blocks make up one large block, which translates into 200 ms. Hence, there are five large blocks per second. A calibration signal may be included with a record. A standard signal of 1 mV must move the stylus vertically 1 cm that is two large squares on ECG paper.

D. Mems:

Micro electro mechanical systems (MEMS) are small integrated devices or systems that combine electrical and mechanical components. Their size range from the sub micrometer (or sub micron) level to the millimeter level and there can be any number, from a few to millions, in a particular system. MEMS extend the fabrication techniques developed for the integrated circuit industry to add mechanical elements such as beams, gears, diaphragms, and springs to devices. Examples of MEMS device applications

include inkjet-printer cartridges, accelerometers, miniature robots, micro engines, locks, inertial sensors, micro transmissions, micro mirrors, micro actuators, optical scanners, fluid pumps, transducers and chemical, pressure and flow sensors. Many new applications are emerging as the existing technology is applied to the miniaturization and integration of conventional devices. These systems can sense, control and activate mechanical processes on the micro scale and function individually or in arrays to generate effects on the macro scale. The micro fabrication technology enables fabrication of large arrays of devices, which individually perform simple tasks, but in combination can accomplish complicated functions.

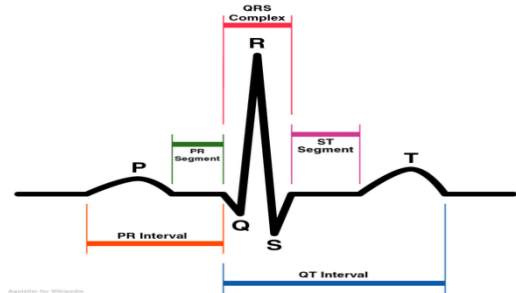

Fig6. Schematic representation of normal ECG

E. Zigbee:

ZigBee is a specification for a suite of high level communication protocols using small, low-power digital radios based on the IEEE 802.15.4-2003 standard for Low-Rate Wireless Personal Area Networks (LR-WPANs), such as wireless light Switches with lamps, electrical meters with in-home-displays, consumer electronics equipment via short-range radio needing low rates of data transfer. The technology defined by the ZigBee specification is intended to be simpler and less expensive than other WPANs, such as Bluetooth. ZigBee is targeted at radio-frequency (RF) applications that require a low data rate, long battery life, and secure networking. ZigBee is a low-cost, low-power, wireless mesh networking standard. First, the low cost allows the technology to be widely deployed in wireless control and monitoring applications. Second, the low power-usage allows longer life with smaller batteries. Third, the mesh networking provides high reliability and more extensive range.

F. Wi-Fi:

It is a local area wireless technology that allows an electronic device to exchange data. The Wi-Fi Alliance defines Wi-Fi as any "wireless local area network" (WLAN) products that are based on the Institute of Electrical and Electronics Engineers' (IEEE) 802.11 standards "Many devices can use Wi-Fi, e.g., personal computers, video-game consoles, Smartphone's, some digital cameras, tablet computers and digital audio players. These can connect to a network resource via a wireless network access point. Such an access point (or hotspot) has a range of about 20 meters (66 feet) indoors and a greater range outdoors. Different competitive brands of access points and client network-interfaces can inter-operate at a basic Level of service.

Products designated as "Wi-Fi Certified" by the Wi-Fi Alliance are backwards compatible. Unlike mobile phones, any standard Wi-Fi device will work anywhere in the world.

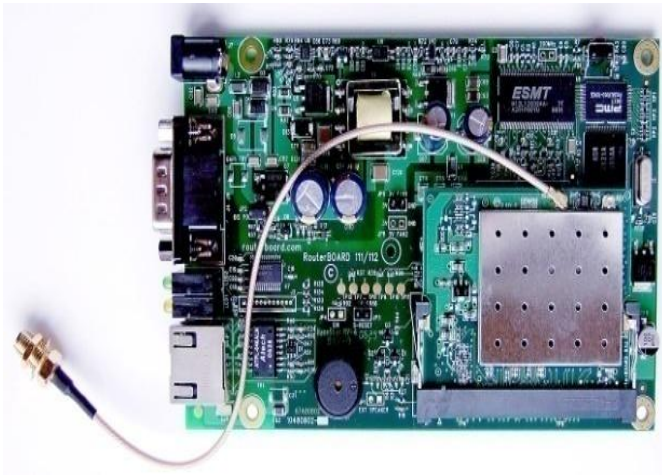

Fig7. Wi-Fi modem.

V. IMPLEMENTATION DETAILS

For instance, a display format on computer for ECG measurement is shown in Fig. The is a MATLAB GUI program includes name of patient, Patient's a Report, frequency domain window displays, also display heart rate in beats per minute. The ECG wave form can be sent further through internet for further analysis. This can bring a great change in Tele-helath field. ECG Waveforms can be seen by using the MATLAB Software.

A. Real time monitoring on Remote side Physician Personal Computer:

The waveform on remote side physician computer is observed by using Wi-Fi panel in a application present on computer so doctor can take access of patient's side computer desktop sharing and reports can be a generated in computer also any one of the vital parameter goes abnormal then alert message will be sent to the doctor section.

B. Results

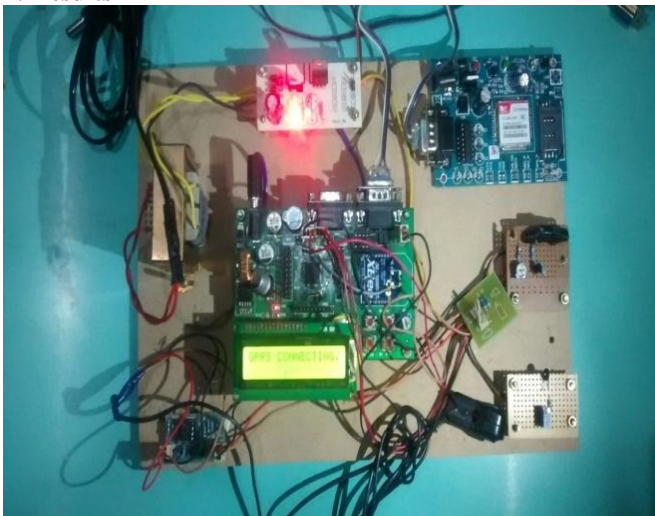

Fig8. Patient section.

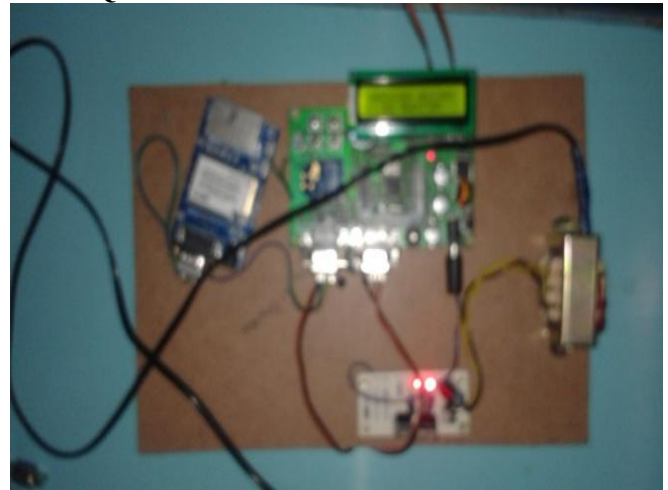

Fig9. Doctor section.

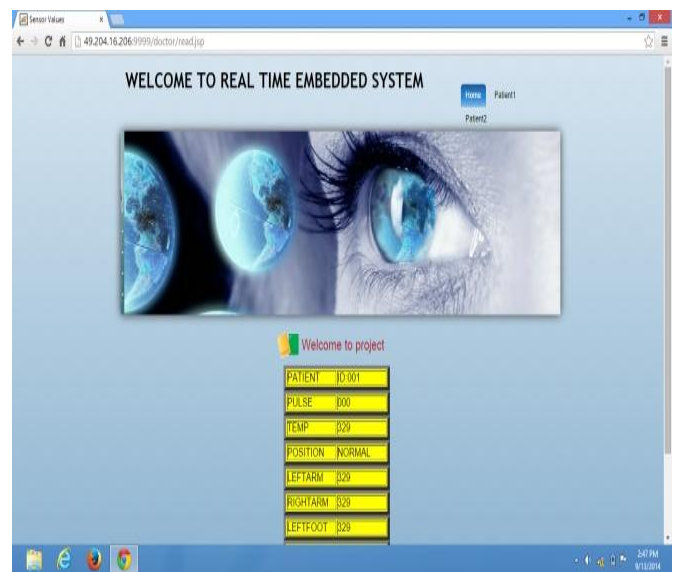

Fig10. Monitoring on web page

VI. CONCLUSION

This system reduce costs by enabling in-home monitoring of patients, eliminating the need for utilization of expensive facilities, and reducing the need for transportation of patients to physicians and medical centers.

VII. REFERENCES

- [1] Ya-lin Miao†, Xiang-lin Miao, Zheng-Zhong Bian, Yongjie Zhang Xi'an Jiaotong University, Xi'an 710049, China "Design and application of Embedded System based on ARM7 LPC2104 Processor in Telemedicine" Proceedings of the 2005 IEEE.
- [2] Ying-Wen Bai, Chien-Yung Cheng, Chou-Lin Lu and Yung-Song Huang, "Design and Implementation of an Embedded Remote ECG Measurement System" IMTC 2005 – Instrumentation and Measurement Technology Conference Ottawa, Canada 17-19 May 2005.
- [3] Nivedita Daimiwal, Asmita Wakankar, Dipali Ramdasi and Mrunal Chandratreya "Microcontroller Based ECG and Blood Pressure Simulator"- J. Instrum. Soc. India 37(4) 243-248.

Design and Implementation of Real Time Patient's Health Monitoring System Based on ARM-7 Processor

- [4] Mohamed Fezari, Mounir Bousbia-Salah, and Mouldi Bedda "Microcontroller Based Heart Rate Monitor" The International Arab Journal of Information Technology, Vol. 5, No. 4, October 2008.
- [5] M. Chaitanya Suman, K. Prathyusha "Wireless ECG System Based on ARM LPC 2103 Processor" IJECT Vol. 3, Issue 1, Jan. - March 2012, ISSN: 2230-7109 (Online) | ISSN : 2230-9543 (Print).
- [6] M. B. I. Reaz "Tele-Health ECG Monitoring System: A Low-cost Approach" International Islamic University Malaysia, Kuala Lumpur, Malaysia.
- [7] C.S. Burrus, R.A. Gopinath, H. Guo, (1997) Introduction to Wavelets and Wavelet Transforms, a Primer, Prentice Hall Inc.
- [8] R.S. Khandpur, Handbook of Biomedical Instrumentation.
- [9] Ramakant Gayakwad, "Linear Integrated circuit", PH hall publication.
- [10] Ya-lin Miao, Xiang-lin Miao, Zheng-Zhong Bian , Yongjie Zhang. Design and Application of Embedded System Based on ARM7 LPC2104 Processor in Telemedicine. Proceedings of the 2005 IEEE Engineering in Medicine and Biology 27th Annual Conference Shanghai, China, September 1-4, 2005.
- [11] Gouaux, F.; Simon-Chautemps, L.; Adami, S.; Arzi, M.; Assanelli, D.; Fayn, J.; Forlini, M.C.; Malossi, C.; Martinez, A.; Placide, J.; Ziliani, G.L.; Rubel, P.;" Smart devices for the early detection and interpretation of cardiological syndromes", Information Technology Applications in Biomedicine, 2003. 4th International IEEE EMBS Special Topic Conference on, 24-26 April 2003, pp. 291-294.
- [12] Celler B., "Remote Monitoring of Health Status of the Elderly at Home," International Journal of Biomedical Computing, vol. 40, no. 2, pp. 147-153, 1995.
- [13] Wang Ping, Wang Jin-gang, Shi Xiao-bo, He Wei. The Research of Telemedicine System Based on Embedded Computer. Proceedings of the 2005 IEEE Engineering in Medicine and Biology 27th Annual Conference Shanghai, China, September 1-4, 2005.
- [14] Choi W., Kim H., and Min B., "A New Automatic Cardiac Output Control Algorithm for Moing Actuator Total Artificial Heart by Motor Current Waveform Analysis," International Journal of Artificial Organs, vol. 19, no. 3, pp. 189-197, 1996.
- [15] A. Istanbulu, P.A. Oner, I. Kocaturk, I. Ozcan "Low Cost ECG Monitoring Experiment Set-Up for Nonclinical Applications" OPTIM 2008 1-4244-1545-4/08/\$25.00 ©2008 IEEE.
- [16] A. L. F. Sparenberg¹, T. Russomano¹, D.F.G. de Azevedo, "Transmission of Digital Electrocardiogram (ECG) via Modem Connection, in Southern Brazil".

Author's Profile:



K.SAIKUMAR has received the B. Tech degree in Electronics & Communication Engineering from Nimra Institute of Engineering and Technology affiliated to University of ANU. He is currently pursuing M.Tech in Embedded systems from CMR Engineering College.
E-mail: saikumar713@gmail.com



Mr. Vaseem Ahmed Qureshi received his B.Tech degree in Electronics & Communication Engineering from Jawaharlal Nehru Technological University, Hyderabad in 2005 and M.Tech degree in VLSI System Design from Jawaharlal Technological University, Hyderabad in 2008. He is working as Associate Professor in the Department of Electronics & Communication Engineering in CMR Engineering College, Hyderabad and has more than 08 years of teaching experience. His research area includes Low Power VLSI Design and Analog IC Design.
E-mail: qureshi.vaseem@gmail.com.