

An Intelligent Industrial Network Support using RTOS Technology

S. RADHIKA¹, Y. MURALI MOHAN BABU²

¹PG Scholar, Dept of ECE, SVCET, Chittoor, AP, India, E-mail: radhika.suru999@gmail.com.

²Professor, Dept of ECE, SVCET, Chittoor, AP, India, E-mail: kisanmohanece@gmail.com.

Abstract: This paper is an RTOS based architecture designed for the purpose of data transmission between two controlling units through IWSN without collision. RTOS is a Process which will be done between hardware and application. Here, stack is the one which is used to avoid the independency of the layers from one with another inside the protocol comes under the standard IEEE802.15.4. Stack having two techniques (PAL and NILI) we are using in the IEEE 802.15.4 to reduce the collision and timing. Mostly, during the packets transmission some collision may occur. This collision has to be avoided to prevent the data loss during the transmission.

Keywords: LPC2148, RTOS, WSN, SCADA.

I. INTRODUCTION

The project deals with the data transmission between two units in the exact time without any collision. The data transmission time is increased with the protocol standard. One of the section runs with RTOS and LPC2148 as master node and another as normal data acquisition node to which sensors are connected. Data acquisition node uses the Peripheral Interface controller. Communications between two nodes (hardware and application) are accomplished through IEEE 802.15.4. The RTOS is to manage the allocation of these resources to users in an orderly and controlled manner. This wireless sensor node is composed of a micro-processors, transceivers, displays and analog to digital converters. Sensor nodes are deployed for industrial process monitoring and control. The sensing parameters can be displayed as graph in Master node as shown in Fig.1.

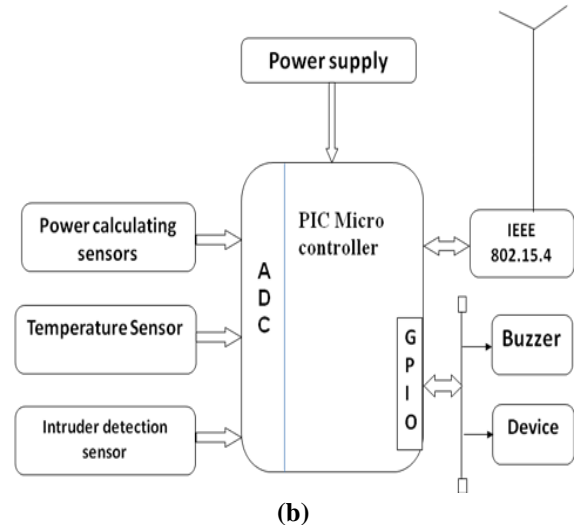
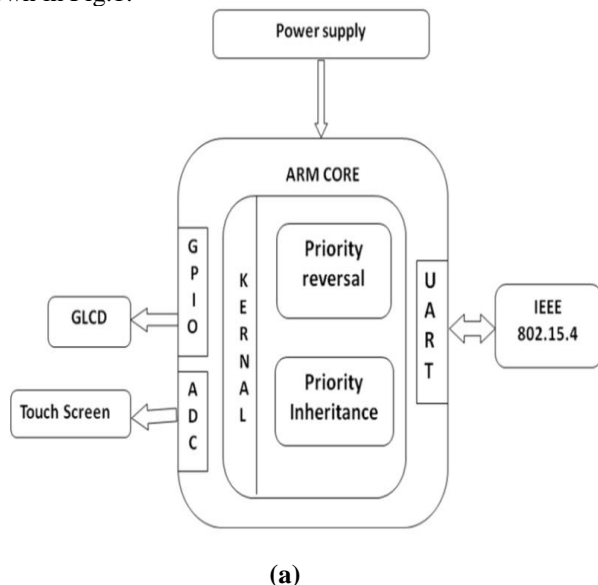

Fig.1. Block diagram (a) Master node and (b) Data acquisition node.

II. TEMPERATURE SENSOR

The LM35 series are precision integrated-circuit temperature sensors, whose output voltage is linearly proportional to the Celsius (Centigrade) temperature. The LM35 thus has an advantage over linear temperature sensors calibrated in ° Kelvin, as the user is not required to subtract a large constant voltage from its output to obtain convenient Centigrade scaling. The LM35 does not require any external calibration or trimming to provide typical accuracies of $\pm 1/4^\circ\text{C}$ at room temperature and $\pm 3/4^\circ\text{C}$ over a full -55 to $+150^\circ\text{C}$ temperature range. Low cost is assured by trimming and calibration at the wafer level. The LM35's low output impedance, linear output, and precise inherent calibration make interfacing to readout or control circuitry especially easy. It can be used with single power supplies, or with plus and minus supplies. As it draws only

60 μ A from its supply, it has very low self-heating, less than 0.1°C in still air. The LM35 is rated to operate over a -55° to +150°C temperature range, while the LM35C is rated for a -40° to +110°C range (-10° with improved accuracy). The LM35 series is available packaged in hermetic TO-46 transistor packages, while the LM35C, LM35CA, and LM35D are also available in the plastic TO-92 transistor package. The LM35D is also available in an 8-lead surface mount small outline package and a plastic TO-220 package.

A. Infrared Sensor

IR LED at 900nm-GaAlAs Infrared Light Emitting Diode- Shines invisible IR light on the user's eye IR 900nm sensor.

- Light Detector
- Detects reflected IR light

We decided to use blinking as we wanted the device to be functional for non-vocal or ventilated users (blowing or sucking was another option). Our first idea, and the one we implemented, was to use a led/photodiode pair to reflect light off the eye. We found that Optec Inc. makes a round receiver, consisting of a LED and a photo transistor mounted on the same unit. This detected a strong increase in signal upon blinking. We were worried about detecting the difference between normal and intentional blinks, but we found that for most users the intentional blinks produced a much stronger signal, and they were always much longer the ~300ms normal blink duration.

B. Signal Conditioner

A signal conditioner is a device that converts one type of electronic signal into a another type of signal. Its primary use is to convert a signal that may be difficult to read by conventional instrumentation into a more easily read format. In performing this conversion a number of functions may take place. They include: Amplification When a signal is amplified, the overall magnitude of the signal is increased. Converting a 0-10mV signal to a 0 - 10V signal is an example of amplification. Electrical Isolation Electrical isolation breaks the galvanic path between the input and output signal. That is, there is no physical wiring between the input and output. The input is normally transferred to the output by converting it to an optical or magnetic signal then it is reconstructed on the output. By breaking the galvanic path between input and output, unwanted signals on the input line are prevented from passing through to the output. Isolation is required when a measurement must be made on a surface with a voltage potential far above ground. Isolation is also used to prevent ground loops Linearization Converting a non-linear input signal to a linear output signal. This is common or thermocouple signals Excitation Many sensors require some form of excitation for them to operate.

Strain gages and RTDs are two common examples. The signal conditioning unit accepts input signals from the analog sensors and gives a conditioned output of 0-5V DC corresponding to the entire range of each parameter. This unit also accepts the digital sensor inputs and gives outputs

in10 bit binary with a positive logic level of +5V. The calibration voltages* (0, 2.5 and5V) and the health bits are also generated in this unit. The unit is powered through DCSTS unit. The DCSTS unit controls the entire operation of a DCP field station. It consists of power supply regulator, timing generator, control logic circuit, multiplexer-cum-A/D converter, health monitor circuit, memory, pseudo-random burst sequence generator and a UHF transmitter. It operates on +12V uninterrupted power. The hourly sequence of operations performed by DCSTS is as given below:

- Provides +12V switched power to signal conditioner 3 minutes and 30 secretor to full hour.
- Converts the calibration voltages and sensor data (outputs of signal conditioner) into digital form and stores in memory.
- Generates one pseudo random burst command in each three minutes 3-sub-slotduring the allotted ten minutes transmission window of a particular AWS, to enable the random transmission of stored data three times. These data along with station identification code, start and end signals are transmitted to INSAT/Kaplan at carry.

III. GLCD WITH TOUCH SCREEN

The course ECE 476: Microcontroller Design requires many tools that allow its students to fully experience the possibilities of designing projects using Microcontrollers. In order for instructors to design laboratory experiments and demonstrations it is essential that he have the tools necessary to make them as easy to put together as possible. The goal of this project is select a low-cost graphical LCD and design a driver that would allow such experiments and demonstrations to be designed around it. In most of the experiments used for ECE 476, a 16x2 Crystal fonts Alphanumeric LCD is used as the major user output and represents the user interface. Alphanumeric LCDs display characters in pre-designated blocks and the LCD screen and this limits their use to simple number and character displays and crude images drawn from numbers or characters (a bouncing ball using the character 'o' or other such graphical techniques.

IV. RTOS TECHNOLOGY

RTOS is an operating system which is used to perform a task with in a particular time interval i.e. within the specific allocated time. using text). While this is suitable for many applications, there are some which would benefit greatly from an easy to use graphical LCD. Most graphical LCDs are not supported by standard C libraries as are simple alphanumeric displays so it becomes much more time consuming to use them in projects. This can be especially prohibitive during regular laboratory experiments because they are often designed to prove a specific instructive idea, and generating a driver for a graphical LCD cannot be done during the allotted time. This paper and project outline the design of a graphical LCD driver for the Crystal fontz CFAG12864B series (128 x 64 pixel) graphical display which can be easily modified to drive any Samsung KS0108 based graphical LCD. It is a real time operating system. A real-time OS that can usually

An Intelligent Industrial Network Support using RTOS Technology

or generally meet a deadline is a soft real-time OS, but if it can meet a deadline deterministically it is a hard real-time OS. Compared with OS and RTOS, RTOS only supports the multitasking operations and time scheduling tasks.

Real-time OS is the level of its consistency concerning the amount of time it takes to accept and complete an application's task. If we are implementing any task without RTOS, it is less accuracy and time delay of the specified time and normally it can possible to perform only one task at a time. So in normal operations systems perform a task one by one. So we are implementing our project using real time operating system. The multitasking is a process to perform a more than one application or task at concurrently, it means possible to perform a so many operations at the same time. in the normal operating systems are not supported this type of multitasking. so in this project we are implementing RTOS concepts. a The main advantage of RTOS is multitasking and time scheduling and rescheduling etc. In RTOS due to the internal minimum time delay of the time scheduling process it will give the output within the specified time. However, due to the lack of uniform programming model and system components for these different teams, the migrations costs of a function model from software to hardware are high. But these actions are necessary in the hardware-software partitioning of embedded systems, especially in the prototype designs. To cope with this problem, we adopt a uniform multi-task model and implement UCOS II RTOS (Red- Time Operating System).

V. RELAY CIRCUIT

The coil of a relay passes a relatively large current, typically 30mA for a 12V relay, but it can be as much as 100mA for relays designed to operate from lower voltages. Hence a CB amplifier is used to achieve the current rating of the relay.

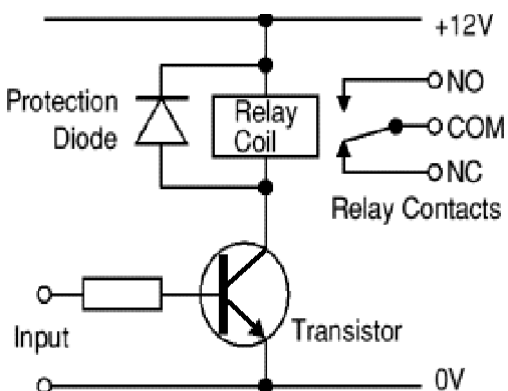

Fig.2. relay circuit.

Transistors and ICs must be protected from the brief high voltage produced when a relay coil is switched off. The Fig.2 shows how a signal diode (e.g. 1N4148) is connected 'backwards' across the relay coil to provide this protection. Current flowing through a relay coil creates a magnetic field which collapses suddenly when the current is switched off. The sudden collapse of the magnetic field induces a brief high voltage across the relay coil which is

very likely to damage transistors and ICs. The protection diode allows the induced voltage to drive a brief current through the coil (and diode) so the magnetic field dies away quickly rather than instantly. This prevents the induced voltage becoming high enough to cause damage to transistors and ICs.

VI. LCD DISPLAY

LCD MODULE (2X16 CHARACTER) matrix liquid crystal {display|LCD|digital display alphanumeric display} modules are employed for display the parameters and fault condition.16 characters two lines show is employed. it's controller that interface data's and LCD panel. liquid displays (LCD's) have materials, that mix the properties of each liquids and crystals. instead of having a freezing point, they need a temperature vary at intervals that the molecules square measure nearly as mobile as they'd be during a liquid, however square measure classified along in AN ordered kind just like a crystal. AN LCD consists of 2 glass panels, with the liquid material sandwiched in between them. The inner surface of the glass plates square measure coated with clear electrodes that outline the character, symbols or patterns to be displayed chemical compound layers square measure gift in between the electrodes and also the liquid molecules to take care of an outlined orientation angle.



Fig.3. seven – LCD Diagram.

One every polarizer's square measure affixed outside the 2 glass panels. These polarizer's would rotate the sunshine rays passing through them to an exact angle, during a explicit direction once the LCD is within the off state, light-weight rays square measure revolved by the 2 polarizes and also the liquid, specified the sunshine rays start up of the LCD with none orientation, and therefore the LCD seems clear. Once comfortable voltage is applied to the electrodes, the liquid molecules would be aligned on a selected direction as shown in Fig.3. The sunshine rays passing through the LCD would be resolved by the polarizes, which might lead to activating/highlighting the required characters.

VII. CONCLUSION

The RTOS is to manage the allocation of these resources to users in an orderly and controlled manner. This wireless sensor node is composed of a micro-processors, transceivers, displays and analog to digital converters. Sensor nodes are deployed for industrial process monitoring and control. The sensing parameters can be displayed as graph in Master node. The basic view of this technique is to reduce the possibility of collision and to meet the critical requirement of timing for data transmission of industrial applications.

VIII. REFERENCES

- [1] WirelessHART standard, HART Communication Foundation. www.hartcomm.org.
- [2] ISA100 standard, International Society of Automation. www.isa.org/isa100.
- [3] WIA-PA standard, Chinese Industrial Wireless Alliance. www.industrialwireless.cn/en/.
- [4] Akerberg, J.; Gidlund, M.; Bjorkman, M. Future research challenges in wireless sensor and actuator networks targeting industrial automation. IEEE Int. Con. on Industrial Informatics (INDIN), 2011, 410-415.
- [5] Xiuming Zhu; Song Han; Mok, A.; Deji Chen; Nixon, M.. Hardware challenges and their resolution in advancing WirelessHART. IEEE Int. Con. on Industrial Informatics (INDIN), 2011, 416-421.
- [6] Edmonds, N.; Stark, D.; Davis, J. "MASS: modular architecture for sensor systems". Int. Sym. Information Processing in Sensor Networks (IPSN), 2005. 393-397.
- [7] Utz Roedig, Sarah Rutledge, James Brown, Andrew Scott, "Towards Multiprocessor Sensor Nodes". ACM Workshop on Hot Topics in Embedded Networked Sensors (HotEmNets '10), 2010.
- [8] Chen, Deji, Nixon, Mark, Mok, Aloysius, WirelessHART™: Real-Time Mesh Network for Industrial Automation (1st ed.), Springer, 2010.
- [9] Jianping Song; Song Han; Mok, A.K.; Deji Chen; Lucas, M.; Nixon, M. Wireless HART: Applying Wireless Technology in Real-Time Industrial Process Control. IEEE Real-Time and Embedded Technology and Applications Symposium, 2008, 377-386.
- [10] PikeOS, SYSGO AG, <http://www.sysgo.com>.