

Realization of Functional Broadside Tests with BIST Technique using a Fixed Hardware Structure

P. SOLOMON CHARLES¹, D. CHANDRAMOHAN², DR.S.BALAJI³

¹PG Scholar, Dept of ECE, CMR Institute of Technology, Hyderabad, Telangana, India, E-mail: pedapudisolomon7@gmail.com.

²Asst Prof, Dept of ECE, CMR Institute of Technology, Hyderabad, Telangana, India, E-mail: chandu.dharmapuri@gmail.com.

³Professor, Dept of ECE, CMR Institute of Technology, Hyderabad, Telangana, India, E-mailsavadham.balaji@gmail.com.

Abstract: Functional broadside tests are two-pattern scan-based tests that avoid over testing by ensuring that a circuit traverses only reachable states during the functional clock cycles of a test. On-chip test generation has the added advantage that it reduces test data volume and facilitates at-speed test application. This paper shows that on-chip generation of functional broadside tests can be done using simple hardware, and can achieve high transition fault coverage for testable circuits. With the proposed on-chip test generation method, the circuit is used for generating reachable states during test application. This alleviates the need to compute reachable states off-line.

Keywords: BIST, On-chip, Built-In Test Generation.

I. INTRODUCTION

Over testing due to the application of two-pattern scan-based tests was described. Over testing is related to the detection of delay faults under non-functional operation conditions. When an arbitrary state is used as a scan-in state, a two-pattern test can take the circuit through state-transitions that cannot occur during functional operation. As a result, slow paths that cannot be sensitized during functional operation may cause the circuit to fail. In addition, current demands that are higher than those possible during functional operation may cause voltage drops that will slow the circuit and cause it to fail. In both cases, the circuit will operate correctly during functional operation. Functional broadside tests ensure that the scan-in state is a state that the circuit can enter during functional operation, or a reachable state. As broadside tests, they operate the circuit in functional mode for two clock cycles after an initial state is scanned in. This results in the application of a two-pattern test. Since the scan-in state is a reachable state, the circuit goes through state-transitions that are guaranteed to be possible during functional operation. Delay faults that are detected by the test can also affect functional operation.

This alleviates the type of over testing described Test generation procedures for functional and pseudo-functional scan-based tests were described in. The procedures generate test sets for application from an external tester. Functional scan-based tests use. When the circuit-under-test is embedded in a larger design, its primary inputs may be driven by other logic blocks that are part of the same design. In addition, the primary inputs of the circuit-under-test include any external inputs of the design that drive the circuit-under-test. The primary outputs of the circuit-under-

test may drive other logic blocks, or they may be primary outputs of the complete design as shown in Fig.1. For simplicity this paper assumes that primary inputs can be assigned any combination of values.

II. BUILT-IN TEST GENERATION

The built-in test generation method from brings the circuit into reachable states by initializing the circuit into a state denoted by s_{init} , which is the initial state of the circuit for functional operation, and applying a primary input sequence A of a fixed length, L , in functional mode. Let $A=a(0)a(1)\dots a(L-1)$, where $a(u)$ is the primary input vector at clock cycle u , for $0 \leq u < L$. Suppose that application of A takes the circuit through the sequence of states $S(0)s(1)s(2)\dots s(l)$, where $s(0)=S_{init}$. For $0 \leq u < L$, $s(u+1)$ is the next-state obtained when the circuit is in present-state and the primary input vector $a(u)$ is applied.

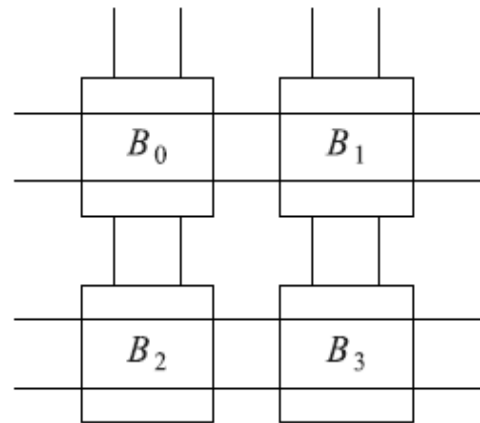

Fig.1. Example of Logic Blocks.

The primary input sequence A is generated by an LF SR whose states are used as pseudo-random vectors. The LFSR sequence is modified in order to avoid an effect called repeated synchronization, where certain primary input values cause certain state variables to assume the same values repeatedly. The logic for generating the primary input sequence A is illustrated by Fig. 2. For a parameter denoted by d, a distinct set of d bits of the LFSR is used for determining the sequence applied to every primary input. For a parameter denoted by mod, up to mod of the d bits dedicated to each primary input are used for avoiding repeated synchronization. If the value 0 on a primary input synchronizes fewer state variables than the value 1, then the value 0 is preferred. In this case, a mod-input AND gate is used for ensuring that a 0 appears more often than a 1 on this primary input. A mod-input OR gate is used for the primary input if the value 1 synchronizes fewer state variables, and it is thus the preferred value for the primary input. No gate is used if both values synchronize the same number of state variables. For a circuit with n primary inputs, this method requires an LF SR with d n bits, and at most one mod-input gate for every primary input. The preferred values of the primary inputs are captured in a primary input cube denoted by c. For a primary input j, c(j) indicates its preferred value, which may be 0, 1 or x.

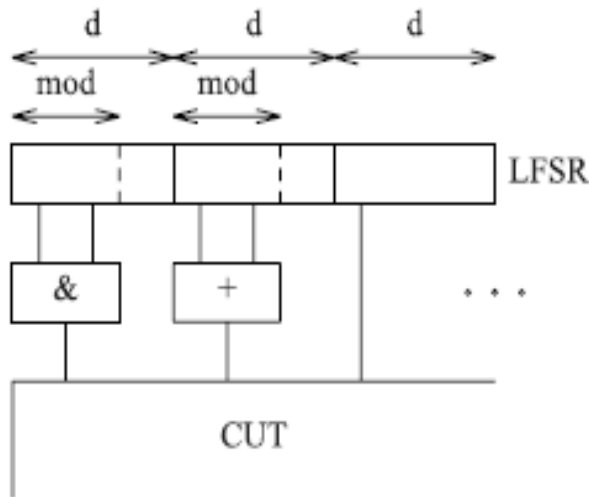

Fig.2. Test Generation Logic.

Several primary input sequences are applied by using several different seeds for initializing the LF SR. Each additional sequence results in a different set of functional broadside tests, and helps increase the fault coverage. All the sequences use the same values of the parameters L, d and mod. Consequently, the same logic is used for generating all the tests. To select seeds, the procedure from uses random seeds until the last Q primary input sequences do not increase the fault coverage, for a constant Q. It keeps only seeds that are needed for increasing the fault coverage. Transition faults are considered in. Overall, the built-in test generation method from requires a d, n-bit LFSR, a modulo-L counter, and at most n + 1 gates. The initial state sinit as well as the seeds are assumed to be scanned in before the application of each primary input sequence. Circular shift requires scan chains of equal lengths. This can be achieved by adding dummy flip-flops to the shorter scan chains.

A. BIST Architecture

A typical BIST architecture consists of

- TPG - Test Pattern Generator
- TRA – Test Response Analyzer
- Control Unit

As shown in fig.3 below.

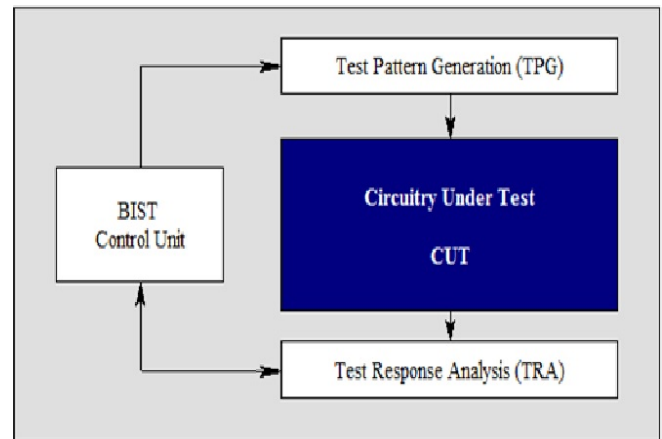

Fig.3. Test Pattern Generator.

It generates test pattern for CUT. It will be dedicated circuit or a micro processor. Pattern generated may be pseudo random numbers or deterministic sequence. Here we are using a Linear Feedback Shift Register for generating random number. The Architecture for LFSR is as shown below Fig.4.

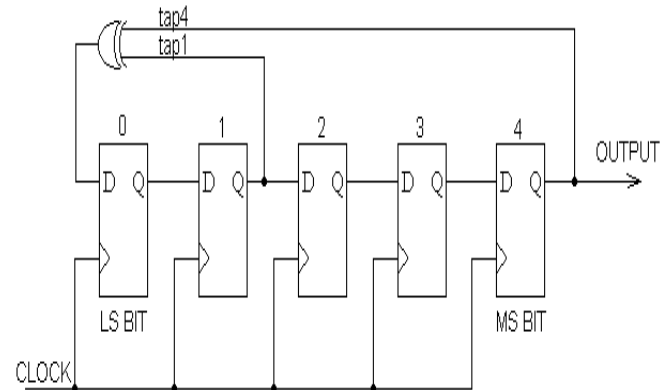

Fig.4. The Architecture for LFSR.

Tapping can be taken as we wish but as per taping change the LFSR output generate will change & as we change in no of flip-flop the probability of repetition of random number will reduce. The initial value loading to the LFSR is known as seed value.

B. Test Response Analyzer (TRA)

TRA will check the output of MISR & verify with the input of LFSR & give the result as error or not.

C. BIST Control Unit

Control unit is used to control all the operations. Mainly control unit will do configuration of CUT in test mode/Normal mode, feed seed value to LFSR, Control MISR & TRA. It will generate interrupt if an error occurs. You can clear interrupt by interrupt_clear_i signal.

Realization of Functional Broadside Tests with BIST Technique using a Fixed Hardware Structure

D. Circuit under Test (CUT)

CUT is the circuit or chip in which we are going to apply BIST for testing stuck at zero or stuck at one error.

1. Need for using BIST Technique: Today's highly integrated multi-layer boards with fine-pitch ICs are virtually impossible to be accessed physically for testing. Traditional board test methods which include functional test, only accesses the board's primary I/Os, providing limited coverage and poor diagnostics for board-network fault. In circuit testing, another traditional test method works by physically accessing each wire on the board via costly "bed of nails" probes and testers. To identify reliable testing methods which will reduce the cost of test equipment, a research to verify each VLSI testing problems has been conducted. The major problems detected so far are as follows:

- Test generation problems
- Gate to I/O pin ratio

- **Test Generation Problems:** The large number of gates in VLSI circuits has pushed computer automatic-test-generation times to weeks or months of computation. The numbers of test patterns are becoming too large to be handled by an external tester and this has resulted in high computation costs and has outstripped reasonable available time for production testing.
- **The Gate to I/O Pin Ratio Problem:** As ICs grow in gate counts, it is no longer true that most gate nodes are directly accessible by one of the pins on the package. This makes testing of internal nodes more difficult as they could neither no longer be easily controlled by signal from an input pin (controllability) nor easily observed at an output pin (observe ability). Pin counts go at a much slower rate than gate counts, which worsens the controllability and observe ability of internal gate nodes.

E. Low Power Pattern Generation

Idea behind low power test pattern generation One way to improve the correlation between the bits of the successive vectors is to avoid frequent transitioning of the logic levels of the primary inputs. The new approach entails inserting 3 intermediate vectors between every two successive vectors. The total number of signal transitions between these 5 vectors is equal to the total number of signal transitions between the 2 successive vectors generated using the conventional approach. This reduction of signal transition activity in the primary inputs reduces the switching activity inside the design under test and therefore results in reduced power Consumption by the device under test. The additional circuitry used to accomplish the generation of the 3 intermediate vectors is minimal at best consisting of few logic gates. The number of LFSR outputs required is driven by the number of test inputs required for circuit under test. The technique of inserting 3 intermediate vectors is achieved by modifying the conventional LFSR circuit with two additional levels of logic between the conventional flip-flop outputs and the low power outputs as shown in Figure 2.10. The first level of hierarchy from the top down includes logic circuit design for propagating either the present or the next

state of the flip-flops to the second level of hierarchy. The second level of hierarchy is a multiplexer function that provides for selecting between the two states (present or next) to be propagated to the outputs as low power output. minimal at best consisting of few logic gates.

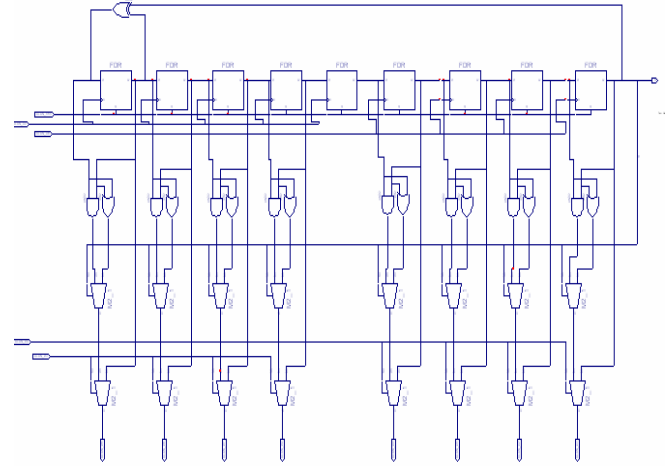

Fig.5. LP-LFSR.

In the simulation environment, the outputs of the flip-flops are loaded with the seed vector. The feedback taps are selected pertinent to the characteristic polynomial $x^8 + x + 1$. Only 2 inputs pins, namely test enable and clock are required to activate the generation of the pattern as well as simulation of the design circuit. It is also noteworthy here that the intermediate vectors in addition to aiding in reducing the number of transitions can also empirically assist in detecting faults just as good as the conventional LFSR patterns. Description of the technique to produce low power pattern for BIST The following is a description of a low power test pattern generation technique as depicted in the 9-bit LFSR based schematic in Fig.5. Verilog based test bench as shown in Appendix B is used in assigning the initial output states (0100 1011) of the 9-bit LFSR. The feedback taps are designed for maximal length LFSR generating all zeros and all one's as well.

The first step is to generate T1, the first vector by enabling (clocking) the first 4-bits of the LFSR and disabling (not clocking) the last 4 bits. This Shifts the first 4 bits to the right by one bit. The feedback bits of the LFSR are the outputs of the 8th and the first flip-flop. The output of the 8th flip-flop is 1 and the output of the first flip-flop is 0. The exclusive-or of the 8th -flip-flop (logic 1 in this case) and the first flip-flop(logic 0 in this case) is input (1 EXOR 0 = 1 into the first D flip-flop. The new pattern in the first four bits of the LFSR is 1010. Note that the shaded register is clocked along with the first 4 bits of the LFSR. So the input of the shaded flip-flop is the output of the 4th flip-flop which in this case is 0. Also note that prior to the first clock, the input of the shaded register was the seed value of the 4th flip-flop at the output of the 4th flip-flop which in this case is 0. So after the first clock this value of 0 will now appear at the output of the shaded flip-flop. In other words the value of the 4th output is stored in this shaded register and is used in the next few

steps. The first 4 shifted bits of the LFSR and the last 4 unshifted bits (i.e. the seed value) are propagated as T1 (1010 1011) to the final outputs. Next few steps involve generating the 3 intermediate patterns from T1. These patterns are defined as Ta, Tb and Tc shown in below fig.6.

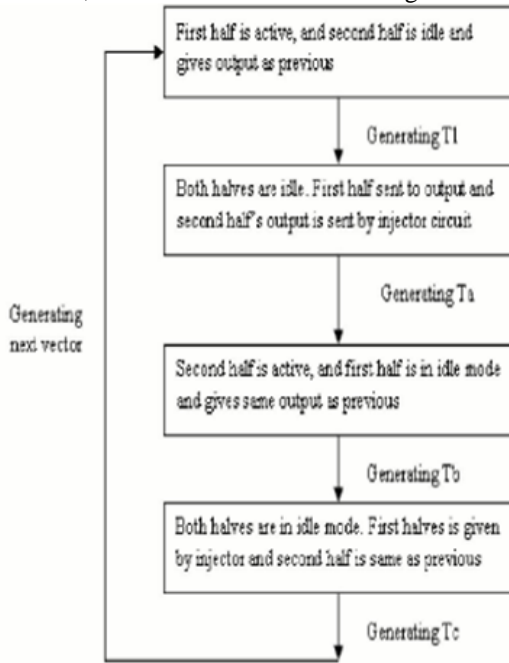

Fig.6. Proposed algorithm for low power LFSR.

Ta is generated by maintaining (disabling the clock to the first 4 bits) the first four bits of the LFSR outputs (as is from T1) as the final first four low power outputs 1010. Note that the clock to the last four bits of the LFSR is also disabled. The last four bits however are the outputs from the injector circuits. The injector circuit compares the next value (the input of the D-flip-flop) with the current value (the output of the D-flip-flop). According to T1, the outputs (current values) of the last 4 bits of the LFSR are 1011. The next values are the values at the inputs of the D-flip-flops which in this case are 0101. Compare the current values (1011) bit by bit with the next values (0101). If the values bit by bit are not the same then use the random generator feedback R (in this case is logic 1) as the bit value as shown in the schematic above. If however both values bit by bit are the same then propagate that bit value to output as opposed to the R bit. This bit by bit comparison gives us the last four bits of Ta to be 1111. Therefore Ta = 1010 1111. Next step is to generate Tb. Shift the last 4 flip-flops to the right one bit but do not shift the first 4 flip-flops to the right. The clock to the first 4 bits plus the shaded flip flop is disabled. The clock to the last 4 bits is enabled. Propagate the outputs of the flip-flops of the entire LFSR as opposed to the outputs of the injection circuit to the outputs (low power).

The injection circuits are disabled. As in Ta, maintain the first four LFSR outputs (1010) as the low power outputs. Again from Ta, the inputs of the last four D flip-flops from the previous step (generating Ta) are 0101. Also note that the output of the shaded register is 0 from the previous step (generating Ta). Therefore the input of the 5th flip-flop is a 0. The outputs of the last 4 flip-flops are 0101 resulting in Tb =

1010 0101. The 3rd intermediate vector Tc is generated via disabling the clock to the entire LFSR. Propagate the first 4 outputs from the injection circuit as the first 4 low power outputs and maintain the last 4 low power outputs the same as Tb. Generating injection circuit outputs for Tc is conceptually the same as explained above in generating Ta. Current values (the outputs of the flip-flops) of the first four flip-flops are compared with the next values (the inputs of the 8th flip-flops) of the flip-flops. The feedback from the 8th flip-flop is 1 (please see generating Tb). Therefore the logical feed forward value of R is 1. The feedback value from the first flip-flop is also 1 as per the current values above. The exclusive or of two ones is a 0. Therefore the input to the first flip-flop is a 0 which is also the next state of the first flip-flop. Hence the next values are 0 for the first flip-flop and 101 for the 2nd, 3rd and 4th flip-flop respectively.

The next values are 0101. The first four outputs from the injection circuit are 1111. The last 4 outputs are the same as Tb which are 0101 resulting in the 3rd and final intermediate vector Tc = 1111 0101. Generating T2 is quite similar to generating T1. As in Tc the outputs of the last four LFSR flops are 0101. The outputs of the first 4 flip-flops of the LFSR are the current values which are 1010. Therefore the seed vector for generating T2 is 1010 0101. Shift the first four bits of the LFSR plus the shaded flip-flop. Do not clock the last four flip-flops. Propagate the outputs of the entire LFSR to the final low power outputs. The output of the 8th flip-flop from the previous step (generating Tc) is a 1 and the output of the first flip-flop from the previous step (generating Tc) is also a 1. The exclusive or of the output of the 8th flip-flop and the first flip-flop is 0. Therefore the input to the first flip-flop will be a 0. The inputs to the 2nd, 3rd, 4th and the shaded flip-flops are 1010. These are also the current values from the previous step (generating Tc). Shifting the first four flip-flops of the LFSR to the right by one bit results in 0101 as the outputs of the first four flip-flops. Therefore T2 generated is 0101 0101.

F. Groups of Logic Blocks

This section considers the built-in generation of functional broad-side tests for groups of logic blocks as shown in Fig.7. The section starts with a discussion of the case where a group G is given. It then considers the selection of groups, and the identification of subsets of seeds for the individual blocks in a group.

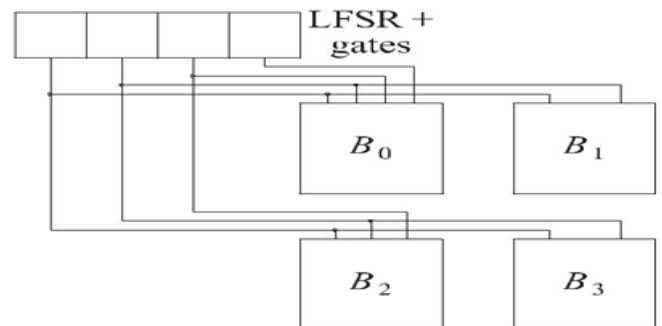

Fig.7. Test Generation Logic for Group.

G. Ripple Carry Adder

Ripple carry adder is an n-bit adder built from full adders. Fig.8 shows a 4-bit ripple carry adder. One full adder is responsible for the addition of two binary digits at any stage of the ripple carry. The carryout of one stage is fed directly to the carry-in of the next stage. Even though this is a simple adder and can be used to add unrestricted bit length numbers, it is however not very efficient when large bit numbers are used.

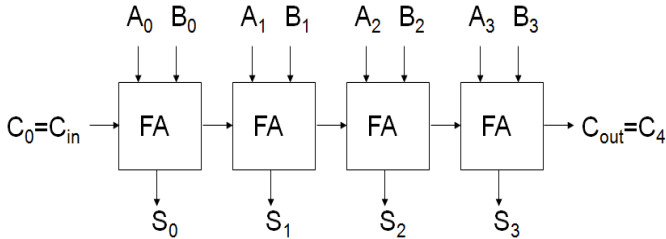

Fig.8.4:4-bRippleCarryAdder.

One of the most serious drawbacks of this adder is that the delay increases linearly with the bit length. The worst-case delay of the RCA is when a carry signal transition ripples through all stages of adder chain from the least significant bit to the most significant bit, which is approximated by:

$$T = (n-1) t_c + t_s \tag{1}$$

III. RESULTS

Results of this paper is as shown in bellow Figs.9 to 11.

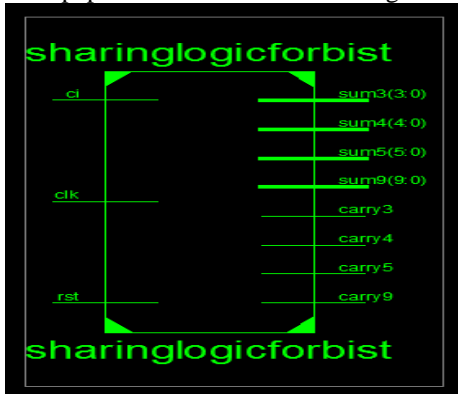

Fig.9. Schematic view.

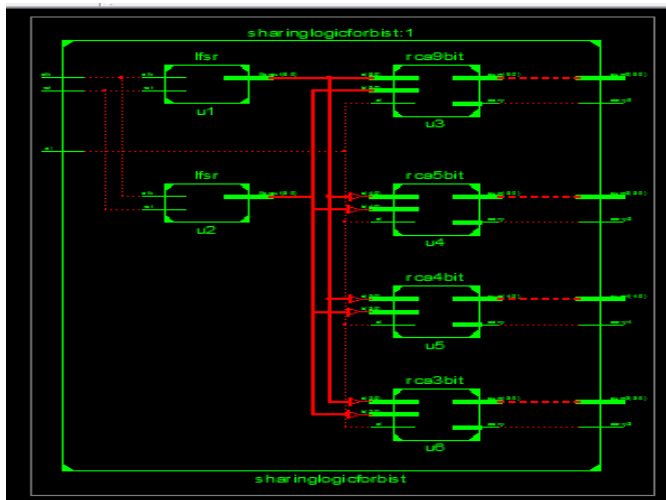

Fig.10. RTL Schematic view.

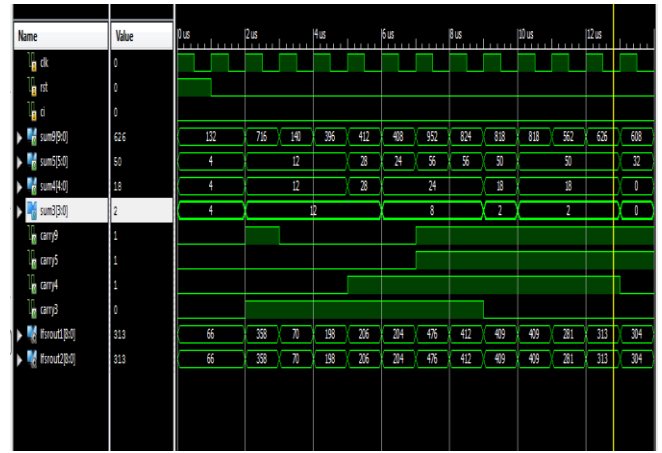

Fig.11. Waveform.

IV. CONCLUSION

The paper studied the built-in generation of functional broad side tests for a design that can be partitioned into logic blocks. In this case, it is advantageous to use the same built-in test generation logic for groups of blocks whose tests have similar characteristics. This implies using the same LFSR, with the same AND and OR gates, and the same seeds, for all the logic blocks in the group. The paper described a procedure for constructing the groups. Considering the set of seeds computed for a group, the paper also identified subsets of seeds that are required for every logic block individually. This is useful for testing a subgroup, for example, if power considerations require smaller groups of logic blocks to be tested simultaneously, or if some of the logic blocks are disabled due to faults that were detected earlier. In future there may be chance to enhance this project by using area optimizing techniques to reduce the area with low cost. The power will be further reduced by using other equivalent reversible logic gates without changing the functionality.

V. REFERENCES

- [1] J. Rearick, "Toomuch delay fault coverage is a bad thing," in Proc. Int. Test Conf., 2001, pp. 624–633.
- [2] J. Saxena, K. M. Butler, V. B. Jayaram, S. Kundu, N. V. Arvind, P. Sreepakash, and M. Hachinger, "A case study of IR-drop in structured-at-speed testing," in Proc. Int. Test Conf., 2003, pp. 1098–1104.
- [3] S. Sde-Paz and E. Salomon, "Frequency and power correlation between at-speed scan and functional tests," in Proc. Int. Test Conf., 2008, pp. 1–9, Paper 13.3.
- [4] I. Pomeranz and S. M. Reddy, "Generation of functional broadside tests for transition faults," IEEE Trans. Comput.-Aided Design Integr. Circuits Syst., vol. 25, no. 10, pp. 2207–2218, Oct. 2006.
- [5] J. Savir and S. Patil, "Broad-side delay test," IEEE Trans. Comput.-Aided Design Integr. Circuits Syst., vol. 13, no. 8, pp. 1057–1064, Aug. 1994.
- [6] I. Pomeranz, "On the generation of scan-based test sets with reachable states for testing under functional operation conditions," in Proc. Design Autom. Conf., 2004, pp. 928–933.
- [7] Y.-C. Lin, F. Lu, K. Yang, and K.-T. Cheng, "Constraint extraction for pseudo-functional scan-based delay testing," in Proc. Asia South Pacific Design Autom. Conf., 2005, pp. 166–171.

[8] M.E. Amyeen, A. Jayalakshmi, S. Venkataraman, S.V. Pathy, and E.C. Tan, "Logic BIST Silicon Debug and Volume Diagnosis Methodology," Proc. Int'l Test Conf., pp. 1-10, 2011.

[9] M. Abramovici, M.A. Breuer, and A.D. Friedman, Digital Systems Testing and Testable Design. IEEE Press, 1995.

[10] P. Girard, "Survey of Low-Power Testing of VLSI Circuits," IEEE Design and Test of Computers, vol. 19, no. 3, pp. 80-90, May/June 2002.

Author's Profile:

P Solomon Charles, Pursuing His M.Tech Degree In CMR Institute Of Technology, Hyderabad and Obtained His B.Tech In Electronics And Communication Engineering From TRR College of Engineering and Technology, Hyderabad , Email: pedapudisolomon7@gmail.com.

D Chandramohan, working As A Assistant Professor In Department of Electronics And Communication Engineering in CMR Institute Of Technology, Hyderabad , Obtained His B.Tech In Electronics And Communication Engineering From Jathipitha College of Engineering and Also Received His M.Tech From Bandari Srinivas Institute of Technology, Email: chandu.dharmapuri@gmail.com.

Dr.S.Balaji, Working As A Professor and Deon of Department of Electronics And Communication Engineering in CMR Institute Of Technology, Hyderabad Received Ph.D From Andhra University, Obtained M.Tech From Osmania University And Also Received B.Tech From Andhra University. Email-id:savadham.balaji@gmail.com.