

A Noval Traffic Management System using IoT and Raspberry Pi3 Microcontroller

Y. KIRAN KUMAR¹, T. DEVI PADMAJA²

¹PG Scholar, Dept of ECE, S V College of Engineering, Tirupati, AP, India, E-mail: yellapallikirankumar@gmail.com.

²Assistant Professor, Dept of ECE, S V College of Engineering, Tirupati, AP, India, E-mail: devipadmaja405@gmail.com.

Abstract: The existing Traffic control system is based on the “time” which is already assigned in the system. According to these times the signals are working in each lane. But in these system condition is occurs as all vehicles in lane(L₁) are passed and vehicles in another lane (L₂) still in waiting state because time is not over and hence signal is still red. These systems are very inefficient because they are unable to handle various simple situations which are occurs throughout the day. Major drawback is it has unnecessary waiting time and there is no facility to handle emergency vehicles. The project is designed to develop a system which performs execution based on density of vehicles (Vehicle Count). After calculating the number of vehicles we will come to know in which side the density is high based on which signals will be allotted for a particular side. Raspberry pi is used as a microcontroller which provides the signal timing based on the traffic density. Raspberry pi directly uploads the Traffic status to the server by using Ethernet connection or Wi-Fi connection. The end user access this data by using GUI designed for specific application. By using webcam it captures the traffic Congestion and emails it to the predefined user.

Keywords: Traffic Management System, Raspberry Pi 3, IoT, Automation.

I. INTRODUCTION

India is the second most populous country in the world and is a fast growing economy. Infrastructure growth is slow as compared to the growth in number of vehicles, due to space and cost constraint. Also, Indian traffic is non-lane based and chaotic. In traffic environments, traffic sign recognition (TSR) is used to regulate traffic signs, warn the driver, and command or prohibit certain actions. Technologies like ZigBee, RFID and GSM can be used in existing traffic control system to provide cost effective solutions. Traffic jams may arise due to large red light delays which are hard corded and is independent of traffic. TRAFFIC flow monitoring and analysis has been active research and engineering topic for more than two decades. Main information acquired from traffic flow monitoring includes: traffic volume, vehicle type identification (bike, car, light van, truck) and vehicle speed. Traffic volume data is used for a variety of purposes including historical trend analysis, forecasting, planning for future infrastructure improvements and expansions. Whereas transport remains the largest producer of CO emissions in EU, traffic monitoring becomes important also from the environmental point of view. Also the World Health Organization has officially decreed that inhaling diesel fumes can cause lung cancer and puts diesel plumes in the same category as arsenic, strontium-90 and neutron radiation. This has given traffic monitoring significant importance. Other traffic data parameters, such as speed and vehicle classification, are becoming more important as a measure of traffic safety and roadway pavement use.

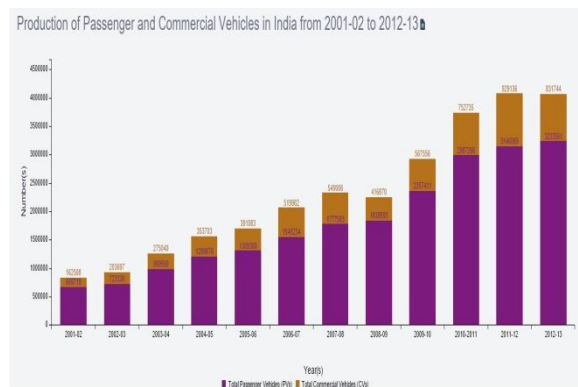

Fig 1. Number of Vehicles in INDIA from 2001-02 to 2012-13.

Recent traffic flow analysis systems are able to perform vehicle number plate recognition which can provide information about main ways of traffic flow through cities and can help to optimize road infrastructure. Collecting this data can be done using a variety of different technologies. Traffic detection technology methods scoring biggest interest in this area includes: Doppler radar (measures the relative velocity of an object moving through its target range), magnetometer sensors (detects vehicles based on the disruption of the Earth’s magnetic field by metal vehicles), video camera (processes images using sophisticated computer algorithms), side-fire radar (side-fire beams placed along a roadway reflect back to the sensor to detect vehicles), pneumatic tubes (transmits information to a counting device after a pulse is created when vehicles drive over a tube). The above statistics shows that automobile

usage in India increased significantly after the liberalization of the Indian Economy. Particularly, Automobile Production has increased by leaps and bounds during 2001-02 to 2012-13. India is the one of the largest producers of automobiles in the world. In order to overcome traffic jam by increase in number of vehicles we require an efficient and sophisticated system as shown in Fig.1. With the advent of powerful single board computers like: OLinuXino, Galileo, PandaBoard, Raspberry Pi, Odroid and others it is possible to design reliable, low-cost traffic monitoring system. Low-power consumption of these boards ensures possibility to operate from car battery for an extended period of time often more than one week. This paper introduces low-cost non-intrusive option that can collect traffic data based on Raspberry Pi. We have chosen this board for its easy and powerful HD camera handling, good performance to power consumption ratio affordable price and wide community. In this work, an efficient IOT based traffic management system using Raspberry Pi microcontroller is described. The system is implemented on Raspberry pi microcontroller with IR sensors and Webcam to capture traffic congestion.

II. LITERATURE SURVEY

As per author Michal Kochláň AND Michal hondu in "WSN for traffic monitoring using Raspberry Pi board", By using hd camers to detect pedestrians and traffic dencity and assign signaling.[2] As per the author Shivam shinde, Dr, S.D.Lokhande," TRAFFIC CONTROL SYSTEM USING RASPBERRY-PI ", They had utilized the strategy for signal coordinating with utilization of ARM 11 Raspberry pi and Zigbee module [3]. As per the author sittigiri lokesh and prahlad," An Adaptive Traffic Control System Using Raspberry PI",By using Matlab they performed image processing to detect vehicles in traffic and based on that they give signalling using microcontroller[4]. But disadvantage of this model is that we require pc at every signalling point. N. Ding, Q. He, and C. Wu, "Performance measures of manual multimodal traffic signal control," in this case they count the vehicles and based on number of vehicles they give signalling. In this case was conducted is gesture is recognized through 3 axes accelerometer sensor. In "Modelling Traffic Control Agency Decision Behaviour for Multimodal Manual Signal Control Under Event Occurrences" IEEE transactions on intelligent transportation systems author describes the event occurrence based traffic control system in this they use interrupt programming to overcome the traffic congestion.

III. NEED

The high volume of vehicles, the inadequate infrastructure and the irrational distribution of the development are main reasons for increasing traffic jam. The major cause leading to traffic congestion is the high number of vehicle which was caused by the population and the development of economy. Traffic congestion is a condition on road networks that occurs as use increases, and is characterized by slower speeds, longer trip times, and increased vehicular queuing. To make traffic light controllers more intelligent, the emergence of novel technologies such as communication

networks and image processing is being exploited. In order to overcome the above problems we need efficient and sophisticated system to control traffic effectively.

IV. IMPLEMENTATION

After we go through the literature survey we understand that there were so many ways to control traffic signaling. In this proposed system we introduced density based traffic control system using IR sensors and Raspberry pi Microcontroller. The block diagram of proposed system is shown in below fig.2.

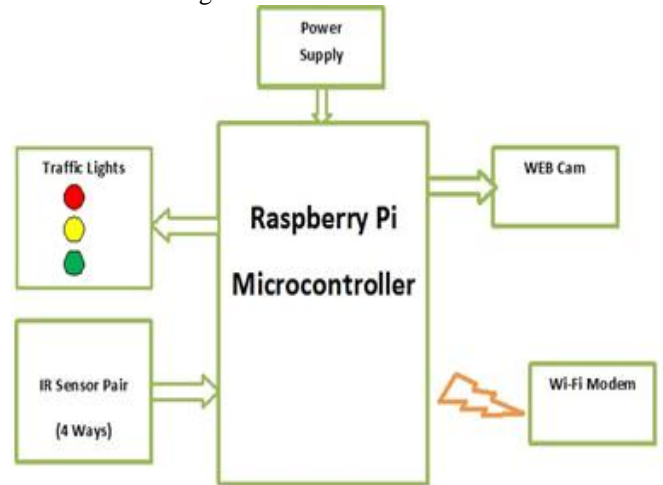

Fig.2. Block diagram of Proposed System.

A. Description

Block diagram consists of Raspberry pi, Web camera, Four IR Pairs with Traffic lights. Web camera interfaced with Raspberry Pi through USB port and used to capture images whenever congestion occurs. The captured images will be processed through python OpenCV library and send this image to predefine mail id using http library. Whenever vehicle crosses the IR sensor then it detects that the traffic exceeds and give signalling to that lane and webcam captures the image of that lane and send it to the email. In this proposed system it's possible to change the mode of the control also from remote location using Thingspeak web based open platform. Two modes are 'auto' and 'manual'. In auto mode system works automatically and give signalling based on congestion.

B. Introduction of Raspberry Pi 3

Raspberry Pi is a credit card sized pocket personal computer with linux operating system manufactured and designed by the Raspberry Pi foundation with an objective of encourage school students and every other person interested in computer hardware to learn basic computer science programming and DIY-Do-it Yourself projects as shown in Fig.3. In this proposed system we have used Raspberry Pi as the controller of image processing. Rpi is the small, inexpensive minicomputer. It continuously captures the images from web camera and process them using pre installed OpenCV software. By using on-chip Ethernet and wi-fi it access internet and send captured image to the pre-defined email ID.

A Noval Traffic Management System using IoT and Raspberry Pi 3 Microcontroller

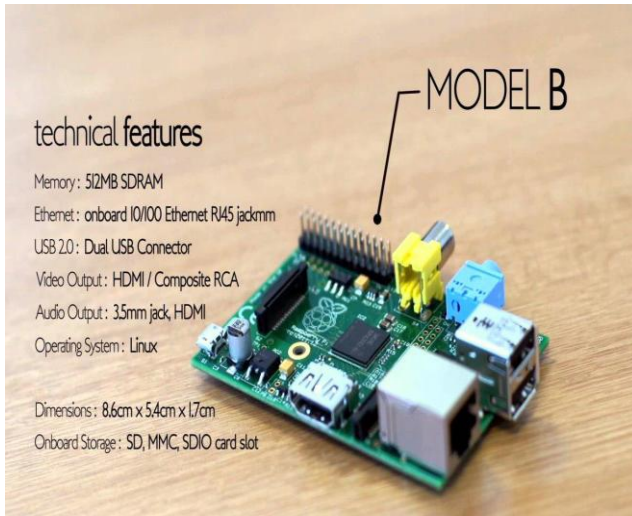

Fig.3. Raspberry Pi 3 Microcontroller.

OpenCV: OpenCV (Open Source Computer Vision) is a library of programming functions mainly aimed at real-time computer vision, developed by Intel Russia research center in Nizhny Novgorod, and now supported by Willow Garage and Itseez. It is free for use under the open source BSD license. The library is cross-platform. It focuses mainly on real-time image processing. If the library finds Intel's Integrated Performance Primitives on the system, it will use these proprietary optimized routines to accelerate itself. OpenCV is written in C++ and its primary interface is in C++, but it still retains a less comprehensive though extensive older C interface. There are now full interfaces in Python, Java and MATLAB/OCTAVE (as of version 2.5). The API for these interfaces can be found in the online documentation. Wrappers in other languages such as C#, Ch, Ruby have been developed to encourage adoption by a wider audience.

Intex Web Camera: Intex webcam night vision 601k is a high resolution USB 2.0 interface camera. Its image resolution is 3280 x 2460 and we can vary it to change resolution according to our requirement. It has some more special features like high quality CMOS sensor to capture images at night time, motion detection and video recording function. Here in our project we used it to capture hand movements as shown in Fig.4.



Fig.4. Intex Webcam.

IR Sensor: An infrared sensor is an electronic device that emits in order to sense some aspects of the surroundings. An IR sensor can measure the heat of an object as well as detects the motion as shown in Fig.5. In our project IR sensor is used to detect the presence of vehicles or pedestrians. When IR light falls on the photodiode, the resistances and these output voltages, change in proportion to the magnitude of the IR light received.

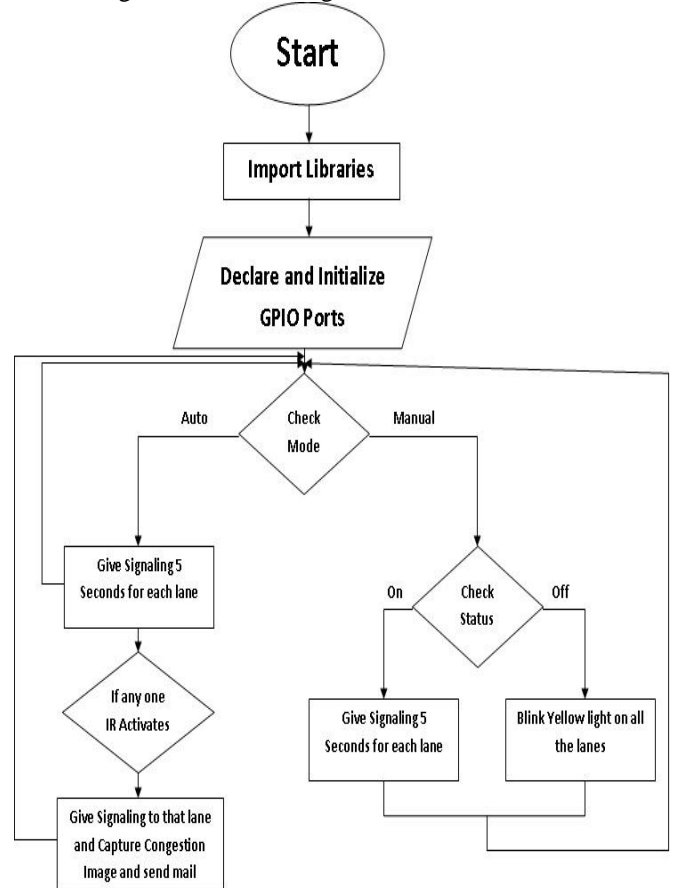

Fig.5. Flow chart of Proposed System.

V. RESULT

The proposed system was fully developed and tested to demonstrate its feasibility and effectiveness. The screenshots and working of the proposed system was shown in below figure. When the kit is at the starting condition it has two conditions ie 1.one side of the three LED's(red, yellow and green) blink constantly for some time 2.when the three LED'S are glown off then 4 red LED'S on the four sides are glown for some until the raspberry pi has to be connected to the internet. This kit is totally controlled by using by using the application Thingspeak application with the help of internet. For controlling the raspberry pi kit by using the Thingspeak application. Project operated in 2 modes

- Auto Mode
- Manual Mode

A. Manual Mode

In manual off mode only yellow color led's are glow these condition is generally occurred during night time because there is no traffic occurred at this time and the density is also

low. In manual on mode condition the led's are glow in the sequential logic during the certain time period for each side. In this condition it doesn't verify in which direction the traffic density is more or in which direction the traffic density is less . It continuously runs with a sequential logic

B. Auto Mode

In auto on mode it verify the condition in which side the traffic density is more. It checks the condition whenever the the signal from transmitter to receiver breaks at the IR sensors then the system allows the traffic move on that path. It also took the image at the ir sensors. These ir sensors are kept at the certain distance from the traffic lights for measuring the density of traffic as shown in Figs.6 and 7.



Fig.6. Total Hardware Kit.

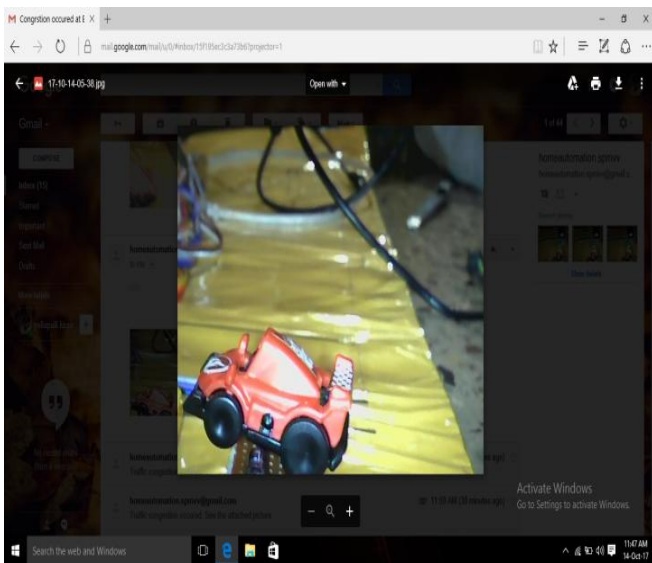

Fig.7. Vehical with Density detection.

VI. CONCLUSION AND FUTURE ENHANCEMENT

A novel traffic management system was designed to reduce the traffic jams using raspberry pi microcontroller, IR sensors and Camera module. This proposed system reduces the possibilities of traffic jams, caused by high red light delays and provides the clearance to vehicles, to an extent

and successfully . Here we designed the system with the purpose to clear the traffic in accordance with priority. In this system, we find the traffic density using IR sensors. The road with the highest priority is cleared first. The proposed system also sends the traffic status to the web server using inbuilt Wi-Fi module. Whenever traffic congestion occurs web cam interfaced with microcontroller capture traffic image and mails to the traffic authority. We control the traffic signal from anywhere using internet if required. In future Higher versions of raspberry pi can be used for reducing the processing time and timer system can also be incorporated. While determining vehicle density if the number of vehicles on any particular side is always less, then each time the lane will be neglected and the waiting time of vehicle on that particular lane will be high. For future expansion this has to be considered.

VII. REFERENCES

[1]T.Litman,“Congestion costing critique:Critical evaluation of the urban mobility report,” Technical Report, 2013.
 [2]K. Mittal and D. Bhandari, “A novel approach to implement green wave system and detection of stolen vehicles,” in Advance Computing Conference (IACC), 2013 IEEE 3rd International. IEEE, Conference Proceedings, pp. 1055–1059.
 [3]Attar, P. Chaudhary, P. Dhuri, K. Vaidya, and N. Venkatesan, “Intelligent traffic management system,” International Education and Research Journal, vol. 1, no. 4, pp. 1–3, 2015.
 [4]P. Handel, J. Ohlsson, M. Ohlsson, I. Skog, and E. Nygren, “Smartphone-based measurement systems for road vehicle traffic monitoring and usage-based insurance,” Systems Journal, IEEE, vol. 8, no. 4, pp. 1238–1248, 2014.
 [5]S. Hebbar, P. Pattar, and V. Golla, “A mobile zigbee module in a traffic control system,” Potentials, IEEE, vol. 35, no. 1, pp. 19–23, 2016.
 [6]P. G. Kaushik, V. D. Dahake, and P. V. Mahalle, “Design of intelligent traffic light controller using fpga,” International Journal of Electronics, Communication and Soft Computing Science & Engineering (IJECSCE), vol. 4, p. 194, 2015.
 [7]“Communications standards news,” IEEE Communications Magazine, vol. 53, no. 9, pp. 5–7, 2015.
 [8]I. Costea, F. Nemtanu, C. Dumitrescu, C. Banu, and G. Banu, “Monitoring system with applications in road transport,” in Design and Technology in Electronic Packaging (SIITME), 2014 IEEE 20th International Symposium for. IEEE, Conference Proceedings, pp. 145–148.
 [9]B. Yang and Y. Lei, “Vehicle detection and classification for low-speed congested traffic with anisotropic magneto resistive sensor,” Sensors Journal, IEEE, vol. 15, no. 2, pp. 1132–1138, 2015.
 [10]R. Sundar, S. Hebbar, and V. Golla, “Implementing intelligent traffic control system for congestion control, ambulance clearance, and stolen vehicle detection,” Sensors Journal, IEEE, vol. 15, no. 2, pp. 1109– 1113, 2015.
 [11]A. Garg, “A novel approach to improve intelligent traffic management system (itms),” in Green Computing and

A Noval Traffic Management System using IoT and Raspberry Pi 3 Microcontroller

Internet of Things(ICGCIoT), 2015 International Conference on. IEEE, Conference Proceedings, pp. 679–682.

[12]R. Kiruthika, S. A. Krishna, K. Balasubramaniam, P. Kumar, and S. R. Kumar, “Automated intellectual road management system using rfid technology,” International Journal of Engineering Science, vol. 3313, 2016.

[13]G. Swathi, G. Sandya, R. Anam, A. Shivakumar, and B. Ashok, “Smart control system of an intelligent traffic signal controller with emergency override,” IJITR, pp.48–52, 2016.

[14]M. T. Garip, M. E. Gursoy, P. Reiher, and M. Gerla, “Congestion attacks to autonomous cars using vehicular botnets,” in NDSS Workshop on Security of Emerging Networking Technologies (SENT), San Diego, CA, Conference Proceedings.

Author’s Profile:



Y. Kiran Kumar is currently pursuing his M.Tech(E.C.E) Embedded system Domain in S.V.College of Engineering, Tirupati. He received his B.Tech degree from MJR College of Engineering and Technology, Piler, AP, India.



T.Devipadmaja received the B.E degree in Electronics & Communications from Priyadarshini College of Engineering, Sullurpet, Nellore, Andhrapradesh, India, in 2008, M.Tech. Degree in Communication Systems from Srinivasa Institute of Technology & Management Studies, Chittoor, Andhra Pradesh, India in 2012. She is currently working as assistant professor in Electronics & Communications Engineering Dept., Sree Venkateswara College of Engineering, Tirupati, Andhra Pradesh, India. Her Research interests include signal and Image processing, IoT Architectures, MEMS, Wireless communications.